

Type 6013 can be combined with...

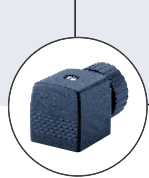

Type 2508
Cable plug





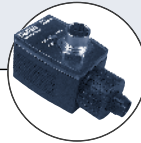

Type 1078
Timer unit



Type 2511
ASI cable plug



Type 8600
Dosage control

- Direct-acting, normally closed
- High cycling rate
- Special versions up to +356°F (+180°C)
- Threaded port and sub-base connections
- Compact design
- Approvals:     

Depending on the model, the direct-acting Type 6013 valve can be flexibly used, either individually or as a valve block, for the shut-off, dosing, filling of various media at temperatures up to 356°F (+180°C). It is also suitable for a technical vacuum.

Power consumption

Coil width DN [mm]	Inrush		Hold		Coil power [W]
	AC [VA]	DC [VA/W]	AC [VA/W]	DC [W]	
32	24	17/8	8	8	
40	30	22/10	10	10	

Manifold mounting

With manifold mounting, please comply with the permissible duty cycle (5 W model with 100% duty cycle or the 8 W model with 60% duty cycle, 30 min).

Attention!

Close open connections for flange valves that are not mounted with covering plates (see Accessories). Secure the manifolds to a supporting plate.

Technical data

Orifice	5/64" - 1/4" (DN 2.0–6.0 mm)
Body materials	Brass Stainless steel
Seal material	FKM, PTFE/graphite (EPDM on request)
Media	Neutral gases and fluids
Media temperature	FKM 14°F to 212°F (-10°C to +100°C) PTFE/Graphite Up to 356°F (+180°C)
Ambient temperature	Max. 131°F (+55°C)
Voltage tolerance	±10%
Duty cycle	100% continuous rating 60% Intermittent operation every 30 minutes with 8 W coil 100% continuous rating with 5 W coil
Electrical connection	Tag connector acc. to DIN 43650 Form A for Type 2508 cable plugs (see Accessories)
Protection class	IP 65 with cable plug
Installation	As required, preferably with actuator upright

Solenoid valve dimensions

Dimensions [mm]						
Port connection	Body			Coil		Coil power [W]
	A	B	C	Width D	Depth E	
NPT 1/8	NPT 1/8	32	20.8	32	45	8
NPT 1/4	NPT 1/4	46	26.8	32	45	8
NPT 3/8	NPT 3/8	50	39.8	40	51	10
Flange	-	32	14.3	32	45	8

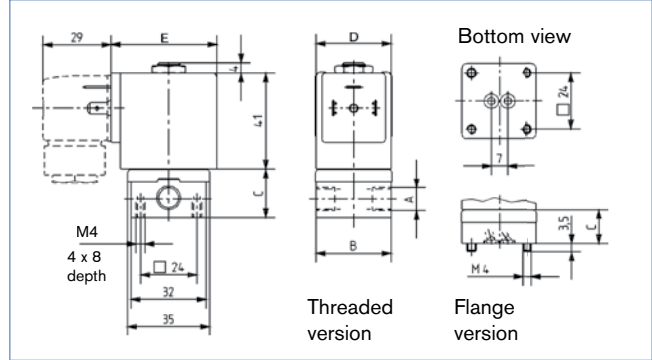

Type 2509 dimension [mm]

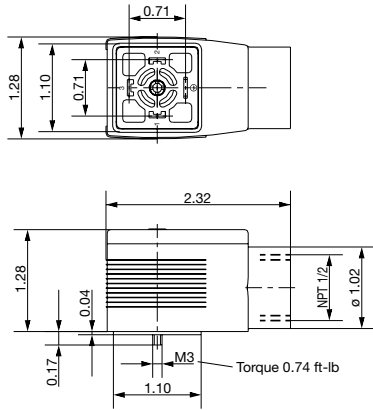

DTS 1000086402 EN Version: - Status: RL (released | freigegeben | valide) printed: 10.08.2006

Ordering chart for valves (other versions on request)
General purpose valves with Brass body and FKM seals

Circuit function	Orifice [mm]	Port connections [NPT]	Cv value [GPM]	Wattage	Pressure range [PSI]	Voltage/frequency [V/Hz]	Item no. UL listed	Item no. UL recognized
A 2/2-way valve NC 	2.0	NPT 1/8"	0.14	8	145	024/DC	456 498	456 307
					145	024/60	456 499	456 308
					145	120/60	456 500	456 309
					145	240/60	456 501	456 310
	2.5	NPT 1/8"	0.19	8	87	024/DC	456 502	456 311
					87	024/60	456 503	456 312
					87	120/60	456 504	456 313
					87	240/60	456 505	456 314
	3.0	NPT 1/8"	0.27	8	87	024/DC	456 506	456 315
					145	024/60	456 507	456 316
					145	120/60	456 508	456 317
					145	240/60	456 509	456 318
	3.0	NPT 1/4"	0.27	8	87	024/DC	456 510	456 319
					145	024/60	456 511	456 320
					145	120/60	456 512	456 321
					145	240/60	456 513	456 322
	4.0	NPT 1/4"	0.35	8	22	024/DC	456 514	456 323
					58	024/60	456 515	456 324
					58	120/60	456 516	456 325
					58	240/60	456 517	456 326
6.0	NPT 3/8"	0.64	10	11	024/DC	-	456 848	
				36	024/60	-	456 849	
				36	120/60	-	456 850	
				36	240/60	-	456 851	

Solenoid valve ordering charts

Ordering chart for valves (other versions on request)

General purpose valves with Stainless Steel body and FKM seals

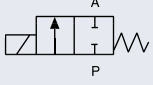
Circuit function	Orifice [mm]	Port connection [NPT]	Cv value [GPM]	Wattage	Pressure range [psi]	Voltage/frequency [V/Hz]	Item no. UL listed	Item no. UL recognized
A 2/2-way valve NC 	2.0	NPT 1/8"	0.14	8	0 - 145	024/DC	456 518	456 327
					0 - 145	24/60	456 519	456 328
					0 - 145	120/60	456 520	456 329
					0 - 145	240/60	456 521	456 330
	3.0	NPT 1/8"	0.27	8	0 - 87	024/DC	456 522	456 331
					0 - 145	24/60	456 523	456 332
					0 - 145	120/60	456 524	456 333
					0 - 145	240/60	456 525	456 334
	3.0	NPT 1/4"	0.27	8	0 - 87	024/DC	456 526	456 335
					0 - 145	24/60	456 527	456 336
					0 - 145	120/60	456 528	456 337
					0 - 145	240/60	456 529	456 338
	4.0	NPT 1/4"	0.35	8	0 - 22	24/DC	456 530	456 494
					0 - 58	24/60	456 531	456 495
					0 - 58	120/60	456 532	456 496
					0 - 58	240/60	456 533	456 497

Ordering chart for valves (other versions on request)

Valves for high temperatures (up to 356 degrees), PTFE/Graphite seal, Brass Body, SS Seat

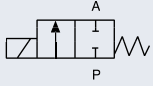
Circuit function	Orifice [mm]	Port connection [NPT]	Cv value [GPM]	Wattage	Pressure range [PSI]	Voltage/frequency [V/Hz]	Item no.
A 2/2-way valve NC 	2.0	NPT 1/4"	0.14	8	0 - 174	024/DC	457 376
					0 - 362	024/60	457 377
					0 - 362	120/60	457 378
					0 - 362	240/60	457 379
	3.0	NPT 1/4"	0.27	10	0 - 115	024/DC	457 380
					0 - 203	024/60	457 381
					0 - 203	120/60	457 382
					0 - 203	240/60	457 383

Coils acc. EEx, UL, CSA etc. Approvals on request.

Solenoid valve ordering chart

Ordering chart for valves (other versions on request)

Valves for Flange versions with Brass Body and FKM seals

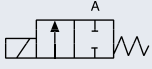
Circuit function	Orifice [mm]	Port connection	Cv value [GPM]	Wattage	Pressure range [PSI]	Voltage/frequency [V/Hz]	Item no. UL listed	Item no. UL recognized
A 2/2-way valve NC 	2.0	Flange	0.14	8	0 - 174	024/DC	457 326	457 310
					0 - 362	024/60	457 327	457 311
					0 - 362	120/60	457 328	457 312
					0 - 362	240/60	457 329	457 313
	3.0	Flange	0.27	8	0 - 87	024/DC	456 696	456 675
					0 - 145	024/60	456 697	456 676
					0 - 145	120/60	456 698	456 677
					0 - 145	240/60	456 699	456 678

Coils acc. EEx, UL, CSA etc. Approvals on request.

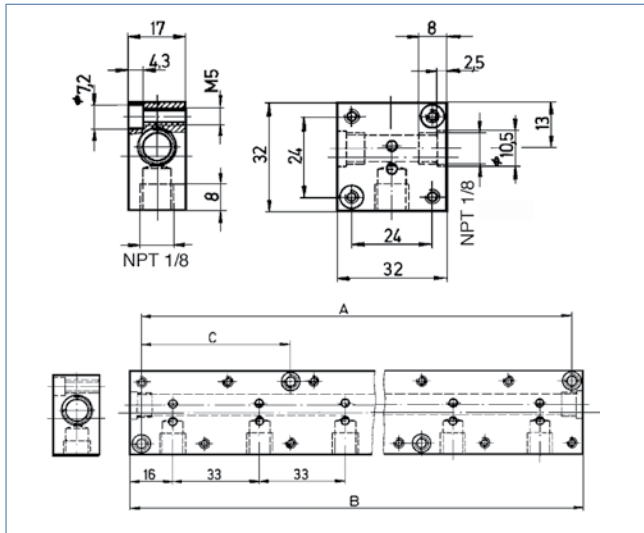

Manifold mounting

With manifold mounting, please comply with the permissible duty cycle (5 W models with 100% continuous rating or 8 W model with 60% duty cycle). The pressure port for the manifold is designated with P (R), and the outlet port with A (B). Only connect together ports with the same designation.

2/2-way valves of Type 6013 can be operated together on a manifold with 3/2-way valves of Type 6014, circuit function C (not D or TI) if the operating pressures agree according to the rating plates. The manifolds can also be expanded if the valve functions are taken into consideration. Connector nipples with O-rings are used to connect the P (R) ports.

Caution! Unused, open valve ports must be closed off with covering plates (see Accessories).

Ordering chart for accessories

Accessory part	Features				Item no.
Single manifold	from aluminium				613 827
Multiple manifold	from aluminium	Hole spacing A [mm]	Total length B [mm]	Hole spacing C [mm]	
	2 valves	57	65	-	006 104
	3 valves	90	98	-	613 828
	4 valves	123	131	-	006 106
	5 valves	156	164	57	613 829
	6 valves	189	197	57	613 598
	8 valves	255	263	57	613 831
	10 valves	321	329	90	613 833
Connector nipple	with O-ring, for connecting manifolds				005 040
Covering plate	with plugs and O-ring, for closing off unused valve positions				005 630

In case of special application conditions, please consult for advice.

We reserve the right to make technical changes without notice.

0602/2_US-en