

## Type 8026 - 8036 - 8076

Flowmeters and Flow transmitters  
Durchfluss-Messgerät oder Durchfluss-Transmitter  
Débitmètres et transmetteurs de débit



## Operating Instructions

Bedienungsanleitung  
Manuel d'utilisation

We reserve the right to make technical changes without notice.  
Technische Änderungen vorbehalten.  
Sous réserve de modification technique.

© 2009-2012 Bürkert SAS

Operating Instructions 1207/01\_EU-ML\_00561367\_Original\_FR

|           |   |           |
|-----------|---|-----------|
| <b>1.</b> | <b>ABOUT THIS MANUAL .....</b>  | <b>4</b>  |
| 1.1.      | <b>Symbols used .....</b>   | <b>4</b>  |
| 1.2.      | <b>Definition of the word "device" .....</b>  | <b>4</b>  |
| <b>2.</b> | <b>INTENDED USE .....</b>   | <b>5</b>  |
| <b>3.</b> | <b>BASIC SAFETY INFORMATION .....</b>   | <b>6</b>  |
| <b>4.</b> | <b>GENERAL INFORMATION .....</b>  | <b>8</b>  |
| 4.1.      | <b>Manufacturer's address and international contacts .....</b>                                  | <b>8</b>  |
| 4.2.      | <b>Warranty conditions .....</b>  | <b>8</b>  |
| 4.3.      | <b>Information on the Internet .....</b>  | <b>8</b>  |
| <b>5.</b> | <b>DESCRIPTION .....</b>  | <b>9</b>  |
| 5.1.      | <b>Area of application .....</b>  | <b>9</b>  |
| 5.2.      | <b>General description .....</b>  | <b>9</b>  |
| 5.2.1.    | <b>Construction of the 8026 .....</b>   | <b>9</b>  |
| 5.2.2.    | <b>Construction of the 8036 .....</b>   | <b>10</b> |
| 5.2.3.    | <b>Construction of the 8076 .....</b>   | <b>10</b> |
| 5.3.      | <b>Description of the name plate .....</b>  | <b>11</b> |
| 5.4.      | <b>Available versions of type 8026 .....</b>  | <b>12</b> |
| 5.5.      | <b>Available versions of the electronic module SE36 .....</b>                                   | <b>13</b> |
| <b>6.</b> | <b>TECHNICAL DATA .....</b>   | <b>14</b> |
| 6.1.      | <b>Conditions of use .....</b>  | <b>14</b> |
| 6.2.      | <b>Conformity to standards and directives .....</b>   | <b>14</b> |
| 6.2.1.    | <b>Conformities common to the 8026 and the SE36 .....</b>                                       | <b>14</b> |
| 6.2.2.    | <b>Conformity to the pressure directive of flowmeters 8026 and fittings S030 and S070 .....</b> | <b>14</b> |
| 6.3.      | <b>General technical data .....</b>   | <b>15</b> |
| 6.3.1.    | <b>Mechanical data .....</b>  | <b>15</b> |
| 6.3.2.    | <b>General data .....</b>   | <b>18</b> |
| 6.3.3.    | <b>Electrical data .....</b>  | <b>19</b> |
| <b>7.</b> | <b>ASSEMBLY .....</b>   | <b>21</b> |
| 7.1.      | <b>Safety instructions .....</b>  | <b>21</b> |
| 7.2.      | <b>Unscrewing the cover .....</b>   | <b>21</b> |

|           |  |           |
|-----------|--|-----------|
| 7.3.      | Mounting the cover .....   | 22        |
| 7.4.      | Mounting the display module.....   | 22        |
| 7.5.      | Dismounting the display module .....   | 23        |
| <b>8.</b> | <b>INSTALLATION AND WIRING.....</b>  | <b>24</b> |
| 8.1.      | Safety instructions .....  | 24        |
| 8.2.      | Installation onto the pipe.....  | 24        |
| 8.2.1.    | Recommendations on installing an 8026 or an 8036 on a pipe.....  | 25        |
| 8.2.2.    | Recommendations on installing an 8076 on a pipe.....   | 26        |
| 8.3.      | Wiring.....  | 27        |
| 8.3.1.    | Electrical connections .....   | 27        |
| 8.3.2.    | Assembling the male or female connector (accessories: .....  | 27        |
| 8.3.3.    | Equipotentiality of the installation .....   | 28        |
| 8.3.4.    | Wiring a version with a single M12 fixed connector and an NPN transistor output and a current output ..... | 29        |
| 8.3.5.    | Wiring a version with a single M12 fixed connector and two transistor outputs and one current output.....  | 30        |
| 8.3.6.    | Wiring a version with two M12 fixed connectors and two transistor outputs and two current outputs.....     | 32        |
| <b>9.</b> | <b>ADJUSTMENT AND COMMISSIONING.....</b>   | <b>35</b> |
| 9.1.      | Safety instructions .....  | 35        |
| 9.2.      | When switching on the device.....  | 35        |
| 9.3.      | Operating levels.....  | 36        |
| 9.4.      | Using the navigation button.....   | 37        |
| 9.5.      | Using the dynamic functions.....   | 38        |
| 9.6.      | Example for the input of a numerical value .....   | 39        |
| 9.7.      | Example for browsing in a menu .....   | 39        |
| 9.8.      | Description of icons and LEDs .....  | 40        |
| 9.9.      | Process level.....   | 41        |
| 9.10.     | Accessing the Configuration level.....   | 42        |
| 9.11.     | Structure of the Configuration menus .....   | 43        |
| 9.12.     | Parameters Menu.....   | 46        |
| 9.12.1.   | Transferring data from one device to another.....  | 46        |
| 9.12.2.   | Modifying the PARAM menu access code.....  | 48        |

- 9.12.3. Restoring the default parameters of the Process level and the outputs ..... 48
- 9.12.4. Setting the data displayed on lines 1 and 2 of the display module..... 48
- 9.12.5. Choosing the units for the totalizers displayed in Process level ..... 50
- 9.12.6. Displaying the lowest and highest values measured ..... 50
- 9.12.7. Setting the parameters for the reading comfort level of the data displayed..... 51
- 9.12.8. Defining the connection mode of the outputs ..... 51
- 9.12.9. Setting the parameters of the current outputs ..... 51
- 9.12.10. Setting the parameters of the transistor outputs ..... 53
- 9.13. Calibration menu ..... 55**
  - 9.13.1. Activating/deactivating the Hold function..... 55
  - 9.13.2. Modifying the Calibration menu access code ..... 55
  - 9.13.3. Resetting totalizer 1 or totalizer 2 respectively..... 56
  - 9.13.4. Adjusting the current outputs..... 56
  - 9.13.5. Entering the K factor or determining it with Teach-in..... 57
- 9.14. Diagnostic menu ..... 60**
  - 9.14.1. Modifying the Diagnostic menu access code..... 60
  - 9.14.2. Monitoring the sensor input frequency..... 60
- 9.15. Test menu ..... 61**
  - 9.15.1. Modifying the Test menu access code..... 61
  - 9.15.2. Checking the outputs functions..... 61
  - 9.15.3. Checking the outputs behaviour..... 62
- 9.16. Information Menu..... 62**
- 10. MAINTENANCE AND TROUBLESHOOTING..... 63**
  - 10.1. Safety instructions ..... 63**
  - 10.2. Cleaning the device ..... 63**
  - 10.3. If you encounter problems ..... 63**
- 11. SPARE PARTS AND ACCESSORIES..... 66**
- 12. PACKAGING, TRANSPORT..... 66**
- 13. STORAGE..... 66**
- 14. DISPOSAL OF THE PRODUCT ..... 67**

MAN 1000182212 EN Version: A Status: RL (released | freigegeben) printed: 19.01.2015

# 1. ABOUT THIS MANUAL

This manual describes the entire life cycle of the device. Please keep this manual in a safe place, accessible to all users and any new owners.

**This manual contains important safety information.**

Failure to comply with these instructions can lead to hazardous situations.

- This manual must be read and understood.

## 1.1. Symbols used



### **DANGER**

**Warns against an imminent danger.**

- Failure to observe this warning can result in death or in serious injury.



### **WARNING**

**Warns against a potentially dangerous situation.**

- Failure to observe this warning can result in serious injury or even death.



### **ATTENTION**

**Warns against a possible risk.**

- Failure to observe this warning can result in substantial or minor injuries.

### **NOTE**

**Warns against material damage.**

- Failure to observe this warning may result in damage to the device or system.



Indicates additional information, advice or important recommendations.



Refers to information contained in this manual or in other documents.

→ Indicates a procedure to be carried out.

## 1.2. Definition of the word "device"

The word "device" used within this manual refers to the flowmeter type 8026, 8036 or 8076.

## 2. INTENDED USE

**Use of the device that does not comply with the instructions could present risks to people, nearby installations and the environment.**

- 8026, 8036 and 8076 devices are intended to measure the flow rate of liquids:
  - 8026 and 8036 flowmeters are used to measure the flow of neutral or slightly aggressive liquids,
  - 8076 flowmeters are used to measure the flow rate of viscous liquids such as honey or oil, which are free of solid particles.
- This device must be protected against electromagnetic interference, ultraviolet rays and, when installed outdoors, the effects of climatic conditions.
- This device must be used in compliance with the characteristics and commissioning and use conditions specified in the contractual documents and in the user manual.
- Requirements for the safe and proper operation of the device are proper transport, storage and installation, as well as careful operation and maintenance.
- Only use the device as intended.

→ Observe any existing restraints when the device is exported.

### 3. BASIC SAFETY INFORMATION

This safety information does not take into account:

- any contingencies or occurrences that may arise during installation, use and maintenance of the devices.
- the local safety regulations for which the operating company is responsible including the staff in charge of installation and maintenance.



#### **Danger due to high pressure in the installation.**

- Stop the circulation of fluid, cut off the pressure and drain the pipe before loosening the process connections.

#### **Danger due to electrical voltage.**

- Shut down and isolate the electrical power source before carrying out work on the system.
- Observe all applicable accident protection and safety regulations for electrical equipment.

#### **Danger due to high temperatures of the fluid.**

- Use safety gloves to handle the device.
- Stop the circulation of fluid and drain the pipe before loosening the process connections.

#### **Danger due to the nature of the fluid.**

- Respect the prevailing regulations on accident prevention and safety relating to the use of aggressive fluids.



#### **Various dangerous situations**

To avoid injury take care:

- to prevent any unintentional power supply switch-on.
- to ensure that installation and maintenance work are carried out by qualified, authorised personnel in possession of the appropriate tools.
- to guarantee a defined or controlled restarting of the process, after a power supply interruption.
- to use the device only if in perfect working order and in compliance with the instructions provided in the instruction manual.
- to observe the general technical rules when installing and using the device.
- not to use the device in explosive atmospheres.
- not to use the device for the measurement of gas flow rates.
- not to use the device in an environment incompatible with the materials it is made of.
- not to use fluid that is incompatible with the materials the device is made of.
- not to subject the device to mechanical loads (e.g. by placing objects on top of it or by using it as a step).
- Do not make any external modifications to the device. Do not paint or varnish any part of the device.



## NOTE

### The device may be damaged by the fluid in contact with.

- Systematically check the chemical compatibility of the component materials of the device and the fluids likely to come into contact with it (for example: alcohols, strong or concentrated acids, aldehydes, alkaline compounds, esters, aliphatic compounds, ketones, halogenated aromatics or hydrocarbons, oxidants and chlorinated agents).

## NOTE

### Elements / Components sensitive to electrostatic discharges

- This device contains electronic components sensitive to electrostatic discharges. They may be damaged if they are touched by an electrostatically charged person or object. In the worst case scenario, these components are instantly destroyed or go out of order as soon as they are activated.
- To minimise or even avoid all damage due to an electrostatic discharge, take all the precautions described in the EN 61340-5-1 and 5-2 norms.
- Also ensure that you do not touch any of the live electrical components.

## **4. GENERAL INFORMATION**

### **4.1. Manufacturer's address and international contacts**

To contact the manufacturer of the device, use following address:

Bürkert SAS

Rue du Giessen

BP 21

F-67220 TRIEMBACH-AU-VAL

You may also contact your local Bürkert sales office.

The addresses of our international sales offices are available on the internet at: [www.burkert.com](http://www.burkert.com)

### **4.2. Warranty conditions**

The condition governing the legal warranty is the conforming use of the in observance of the operating conditions specified in this manual.

### **4.3. Information on the Internet**

You can find the user manuals and technical data sheets regarding the types 8026, 8036 or 8076 at:  
[www.burkert.com](http://www.burkert.com)

## 5. DESCRIPTION

### 5.1. Area of application

8026, 8036 and 8076 devices are intended to measure the flow rate of liquids:

- 8026 and 8036 flowmeters are used to measure the flow of neutral or slightly aggressive liquids,
- 8076 flowmeters are used to measure the flow rate of viscous liquids such as honey or oil, which are free of solid particles.

Thanks to one or two fully adjustable transistor outputs, the device can be used to switch a solenoid valve, activate an alarm and, thanks to one or two 4-20-mA current outputs, establish one or two control loops.

### 5.2. General description

#### 5.2.1. Construction of the 8026

The 8026 flowmeter comprises:

|  |  |
|--|--|
|  | <p>A: a paddle-wheel flow sensor, the rotation of which generates pulses.<br/>Set in rotation by the flow, the 4 permanent magnets integrated in the vanes of the paddle generate pulses, the frequency of which is proportional to the flow speed of the fluid. A conversion coefficient specific to each pipe (material and diameter) is necessary to establish the flow rate value associated with the measurement.</p> <p>The conversion coefficient (Factor K) expressed in pulses per litre is given in the user manual for the fitting used.</p> <p>B: an acquisition / conversion module for the process values measured:</p> <ul style="list-style-type: none"> <li>▪ acquisition of the pulse frequency</li> <li>▪ conversion of the frequency measured into flow rate units</li> </ul> <p>C: a display module with navigation button used to read and/or configure the parameters of the device. The display module is not delivered with all the versions of the flowmeter but it is available as an accessory.</p> <p>See chap. <a href="#">11</a>.</p> |
|--|--|

### 5.2.2. Construction of the 8036

The 8036 flowmeter comprises:

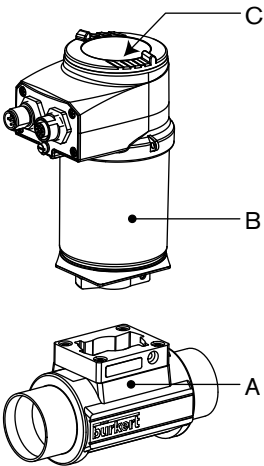
|   |  |
|---|--|
|  | <p>A: an S030 fitting including the paddle-wheel flow sensor.</p> <p>Set in rotation by the flow, the 4 permanent magnets integrated in the vanes of the paddle generate pulses, the frequency of which is proportional to the flow speed of the fluid. A conversion coefficient specific to each pipe (material and diameter) is necessary to establish the flow rate value associated with the measurement.</p> <p>The conversion coefficient (Factor K) expressed in pulses per litre is given in the user manual for the fitting used.</p> |
|   | <p>B: an acquisition / conversion module for the process values measured:</p> <ul style="list-style-type: none"> <li>▪ acquisition of the pulse frequency</li> <li>▪ conversion of the frequency measured into flow rate units</li> </ul>  |
|   | <p>C: a display module with navigation button used to read and/or configure the parameters of the device. The display module is not delivered with all the versions of the flowmeter but it is available as an accessory.</p> <p>See chap. 11.</p>   |

### 5.2.3. Construction of the 8076

The 8076 flowmeter comprises:

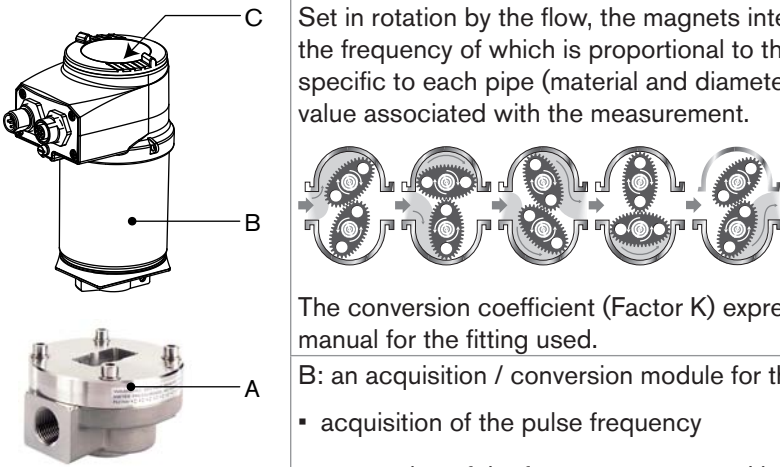
|   |   |
|---|---|
|  | <p>A: an S070 fitting including the flow sensor with oval gears.</p> <p>Set in rotation by the flow, the magnets integrated in the oval gears generate pulses, the frequency of which is proportional to the volume of fluid. A conversion coefficient specific to each pipe (material and diameter) is necessary to establish the flow rate value associated with the measurement.</p> |
|   | <p>The conversion coefficient (Factor K) expressed in pulses per litre is given in the user manual for the fitting used.</p> <p>B: an acquisition / conversion module for the process values measured:</p> <ul style="list-style-type: none"> <li>▪ acquisition of the pulse frequency</li> <li>▪ conversion of the frequency measured into flow rate units</li> </ul>                  |
|   | <p>C: a display module with navigation button used to read and/or configure the parameters of the device. The display module is not delivered with all the versions of the flowmeter but it is available as an accessory.</p> <p>See chap. 11.</p>  |

### 5.3. Description of the name plate

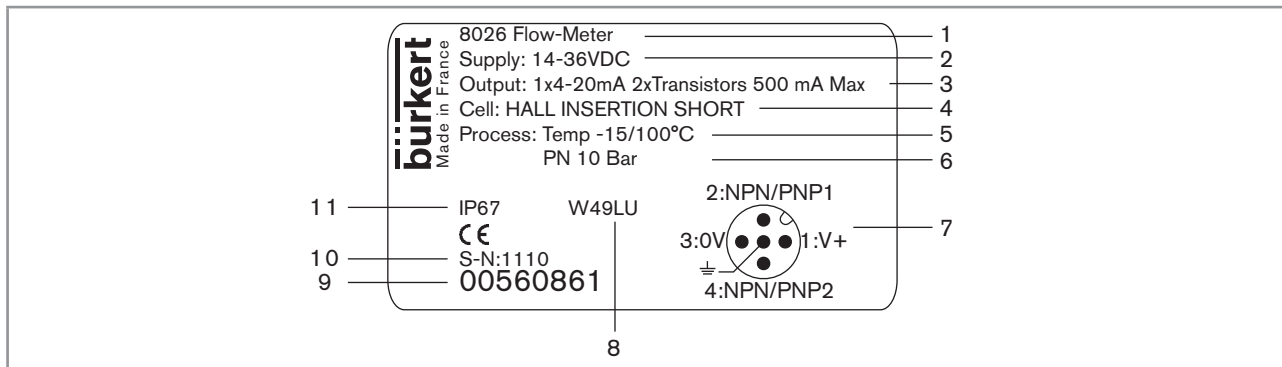





Figure 1 : Example of a name plate

1. Type of the device and measured variable
2. Power supply
3. Output specifications
4. Type of sensor
5. Fluid temperature range
6. Fluid pressure
7. Allocation of the pins on the M12 fixed connectors
8. Manufacturing code
9. Order code
10. Serial number
11. Protection rating

## 5.4. Available versions of type 8026

The following versions of the 8026 flowmeter are available. Each version of the 8026 flowmeter is available without or with the display module.

The display module is also available as an accessory. See chap. 11.

| Voltage supply | Outputs                                | Electrical connection   | Type of sensor | Seal of the sensor | UL   | Type of connection of the outputs | Order code of the 8026 |                     |
|----------------|--|---|----------------|--------------------|--|-----------------------------------|------------------------|---------------------|
|                |  |   |                |                    |  |                                   | without display module | with display module |
| 14-36 V DC     | 1 NPN transistor + 1 x 4-20 mA         | Male 5-pin M12 fixed connector                                    | Short          | FKM <sup>1)</sup>  | no   | 2-wire                            | 560860                 | 561860              |
|                |  |   | Long           | FKM <sup>1)</sup>  |  |                                   | 560870                 | 561870              |
|                |  |   | Short          | FKM <sup>1)</sup>  | yes  | 2-wire                            | 560863                 | 561863              |
|                |  |   | Long           | FKM <sup>1)</sup>  |   |                                   | 560873                 | 561873              |
|                | 2 x transistor, NPN/PNP, + 1 x 4-20 mA | Male 5-pin M12 fixed connector                                    | Short          | FKM <sup>1)</sup>  | no   | 2-wire                            | 560861                 | 561861              |
|                |  |   | Long           | FKM <sup>1)</sup>  |  |                                   | 560871                 | 561871              |
|                |  |   | Short          | FKM <sup>1)</sup>  | yes  | 2-wire                            | 560864                 | 561864              |
|                |  |   | Long           | FKM <sup>1)</sup>  |  |                                   | 560874                 | 561874              |
| 12-36 V DC     | 2 x transistor, NPN/PNP, + 2 x 4-20 mA | Male 5-pin M12 fixed connector + female 5-pin M12 fixed connector | Short          | FKM <sup>1)</sup>  | no   | 3-wire                            | 560862                 | 561862              |
|                |  |   | Long           | FKM <sup>1)</sup>  |  |                                   | 560872                 | 561872              |
|                |  |   | Short          | FKM <sup>1)</sup>  | yes  | 3-wire                            | 560865                 | 561865              |
|                |  |   | Long           | FKM <sup>1)</sup>  |  |                                   | 560875                 | 561875              |



<sup>1)</sup> A set with additional seals (1 green FKM seal + 1 black EPDM seal) is delivered with each device.

## 5.5. Available versions of the electronic module SE36

The following versions of the electronic module SE36, part of the flowmeter 8036 or 8076 are available. The references of the S030 and S070 fittings including the flow sensor can be found on the relevant technical data sheets for these product types.

Each version of the electronic module is available without or with the display module.

The display module is also available as an accessory. See chap. 11.

| Voltage supply | Outputs                                | Electrical connection   | Type of connection of the outputs | UL   | Order code of the SE36 |                     |
|----------------|--|---|-----------------------------------|--|------------------------|---------------------|
|                |  |   |                                   |  | without display module | with display module |
| 14-36 V DC     | 1 NPN transistor + 1 x 4-20 mA         | Male 5-pin M12 fixed connector                                    | 2-wire                            | no   | 560880                 | 561880              |
|                |  |   |                                   | yes<br> | 560883                 | 561883              |
|                | 2 x transistor, NPN/PNP, + 1 x 4-20 mA | Male 5-pin M12 fixed connector                                    | 2-wire                            | no   | 560881                 | 561881              |
|                |  |   |                                   | yes<br> | 560884                 | 561884              |
| 12-36 V DC     | 2 x transistor, NPN/PNP, + 2 x 4-20 mA | Male 5-pin M12 fixed connector + female 5-pin M12 fixed connector | 3-wire                            | no   | 560882                 | 561882              |
|                |  |   |                                   | yes<br> | 560885                 | 561 885             |

## 6. TECHNICAL DATA

### 6.1. Conditions of use

|                     |   |
|---------------------|---|
| Ambient temperature | -10 to +60 °C   |
| Air humidity        | < 85%, non condensated  |
| Protection rating   | IP67 and IP65 with connectors plugged in and tightened and electronic module cover fully screwed down |

### 6.2. Conformity to standards and directives

#### 6.2.1. Conformities common to the 8026 and the SE36

- EMC: EN 61000-6-2, EN 61000-6-3
- Vibration: EN 60068-2-6
- Shock: EN 60068-2-27



For UL devices (  ) in the United States of America and Canada:

- UL 61010-1
- CAN/CSA-C22.2 n° 61010-1

#### 6.2.2. Conformity to the pressure directive of flowmeters 8026 and fittings S030 and S070

The devices 8026 and the fittings S030 and S070 comply with article 3§3 of the pressure directive.

Acc. to the 97/23/CE pressure directive, the product can only be used in the following cases (depending on max. pressure, pipe diameter and fluid):

| Type of fluid             | Conditions  |
|---------------------------|---|
| Fluid group 1, par. 1.3.a | <ul style="list-style-type: none"> <li>▪ Flowmeter 8026 and fitting S030: <math>DN \leq 25</math> only</li> <li>▪ Fitting S070: Forbidden</li> </ul>  |
| Fluid group 2 par. 1.3.a  | $DN \leq 32$<br>or $DN > 32$ and $PN \times DN \leq 1000$   |
| Fluid group 1 par. 1.3.b  | <ul style="list-style-type: none"> <li>▪ Flowmeter 8026: <math>DN \leq 25</math> or <math>DN &gt; 25</math> and <math>PN \times DN \leq 2000</math></li> <li>▪ Fittings S030 and S070: <math>PN \times DN \leq 2000</math></li> </ul> |
| Fluid group 2 par. 1.3.b  | <ul style="list-style-type: none"> <li>▪ Flowmeter 8026: <math>DN \leq 400</math></li> <li>▪ Fittings S030 and S070: <math>DN \leq 200</math></li> </ul>  |



## 6.3. General technical data

### 6.3.1. Mechanical data

| Part   | Material                           |
|--|------------------------------------|
| Box / seals                                    | stainless steel 1.4404, PPS / EPDM |
| Cover / seal                                   | PC / EPDM                          |
| Display module                                 | PC / PBT                           |
| M12 fixed connector                            | nickel-plated brass                |
| Fixed connector holder                         | stainless steel 1.4404 (316L)      |
| Screws   | Stainless steel                    |
| Nut  | PC                                 |
| Flow sensor holder / seal (only 8026)          | PVDF / FKM (default)               |
| Axis and shaft of the paddle wheel (only 8026) | Ceramic ( $Al_2O_3$ )              |
| Paddle wheel (only 8026)                       | PVDF                               |
| Quarter-turn system (only SE36)                | PC                                 |

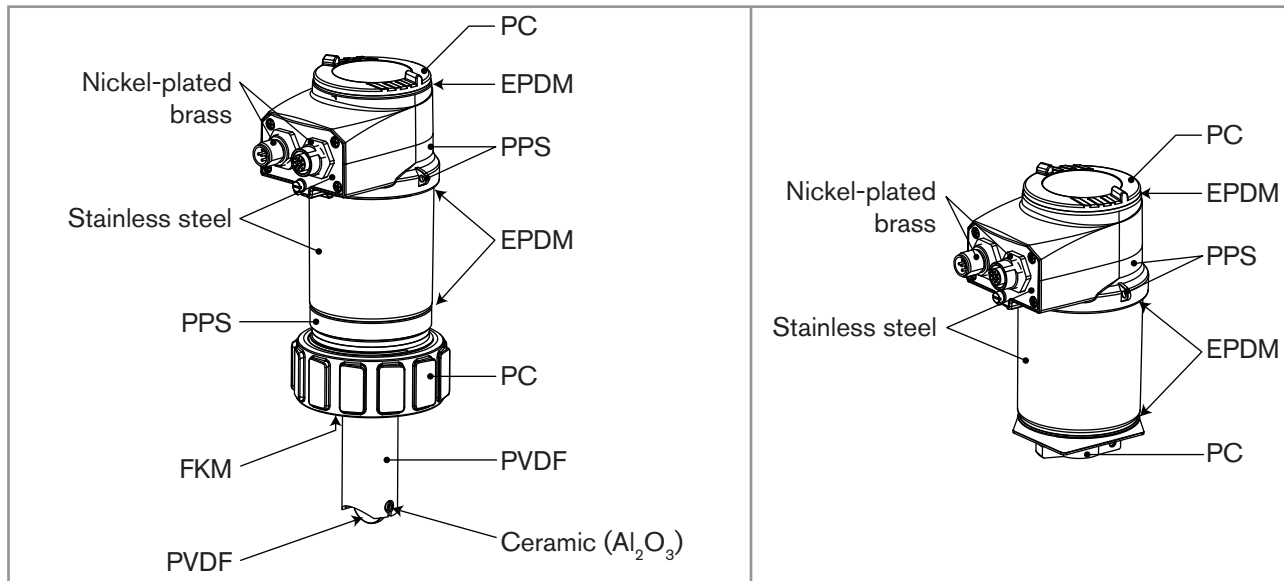

Figure 2 : Materials used in the 8026 flowmeters and the SE36 electronic module for the 8036 or 8076 flowmeters

- Materials of the 8026 in contact with the fluid: PVDF, ceramic, FKM (default).

MAN 1000182212 EN Version: A Status: RL (released | freigegeben) printed: 19.01.2015

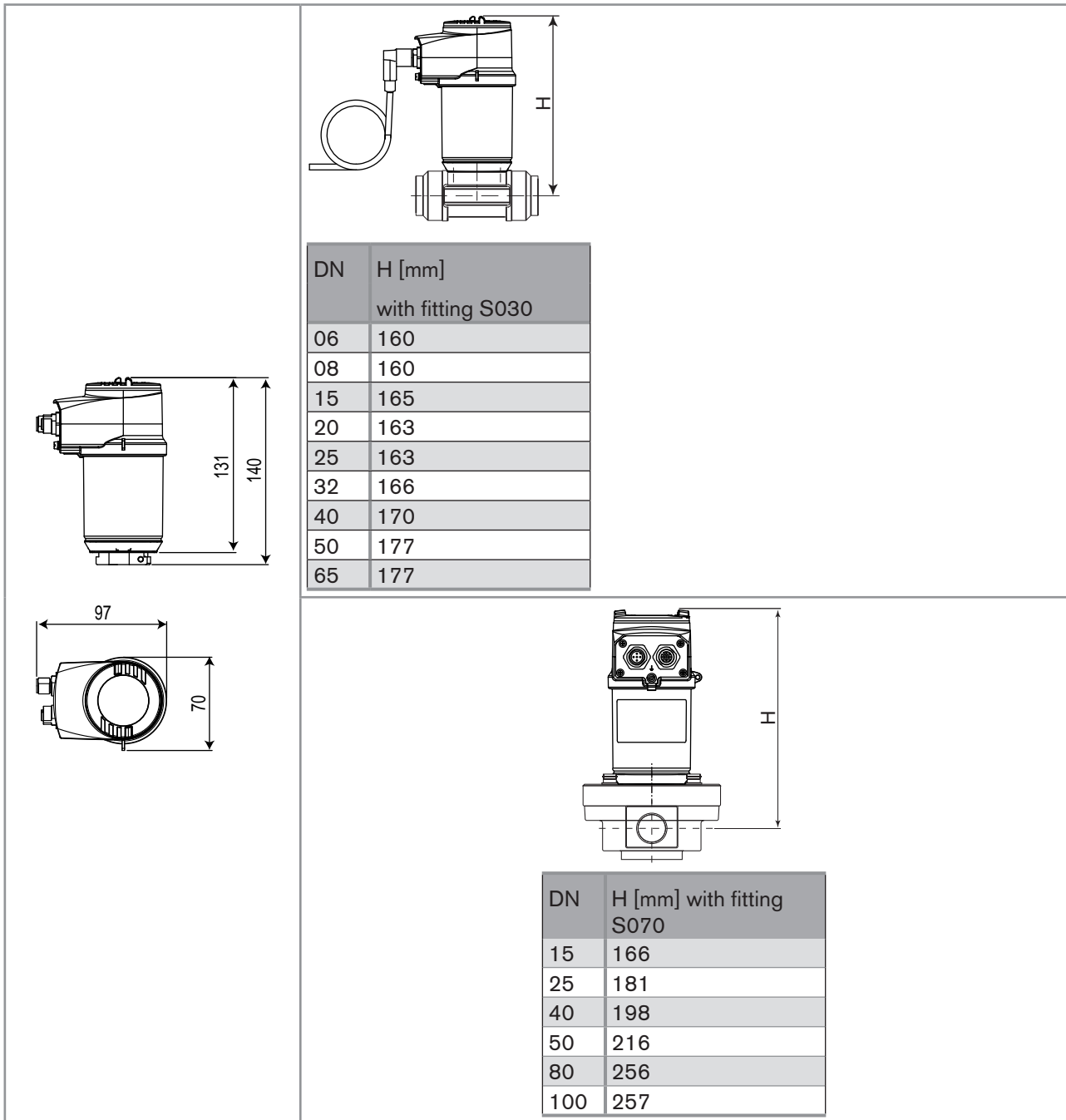

Figure 3 : Dimensions of the electronic module SE36 and dimension H of flowmeters 8036 and 8076

MAN 1000182212 EN Version: A Status: RL (released | freigegeben) printed: 19.01.2015

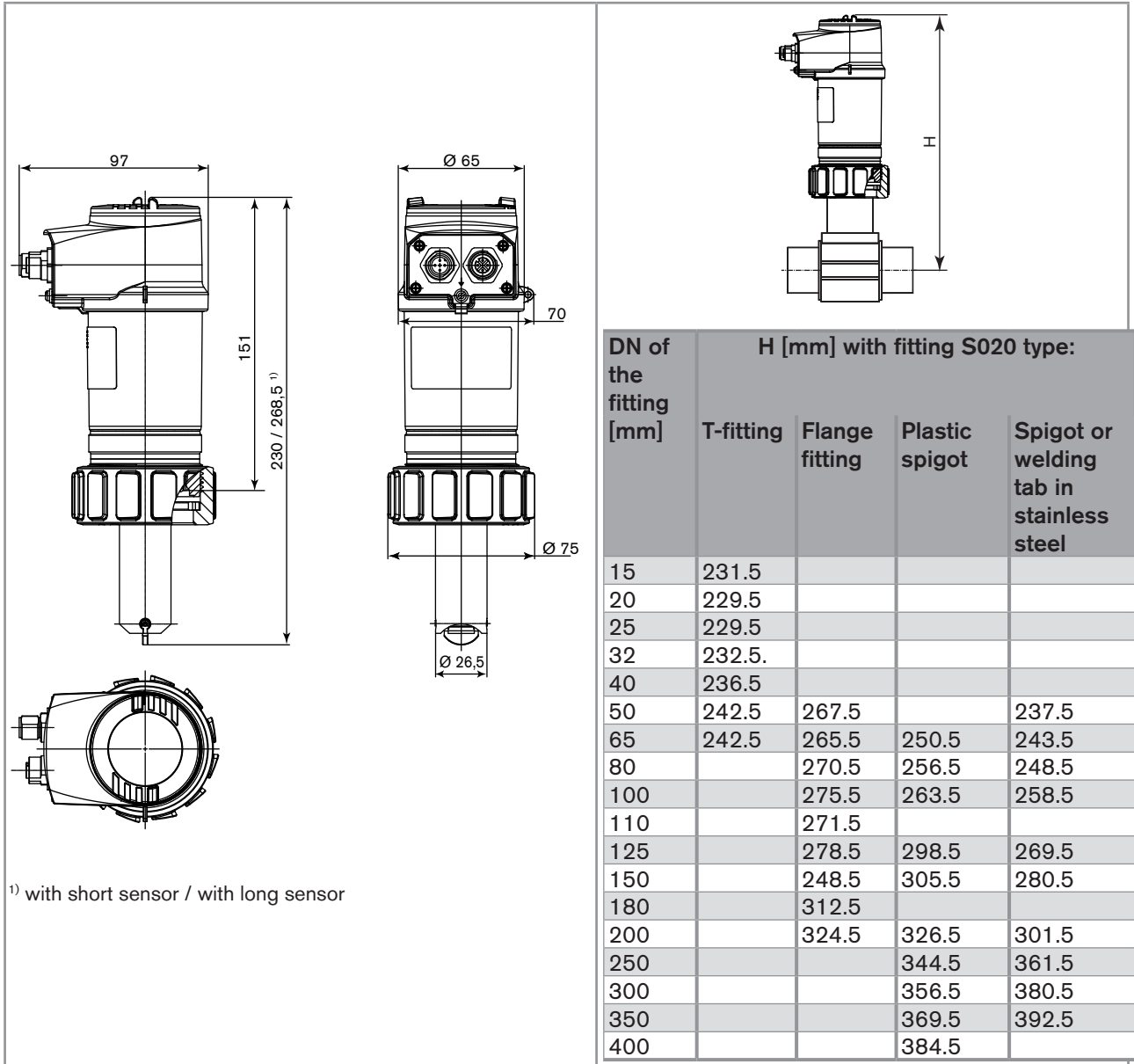

Figure 4 : Dimensions of flowmeters 8026 and dimension H when the flowmeter 8026 is inserted into a fitting S020

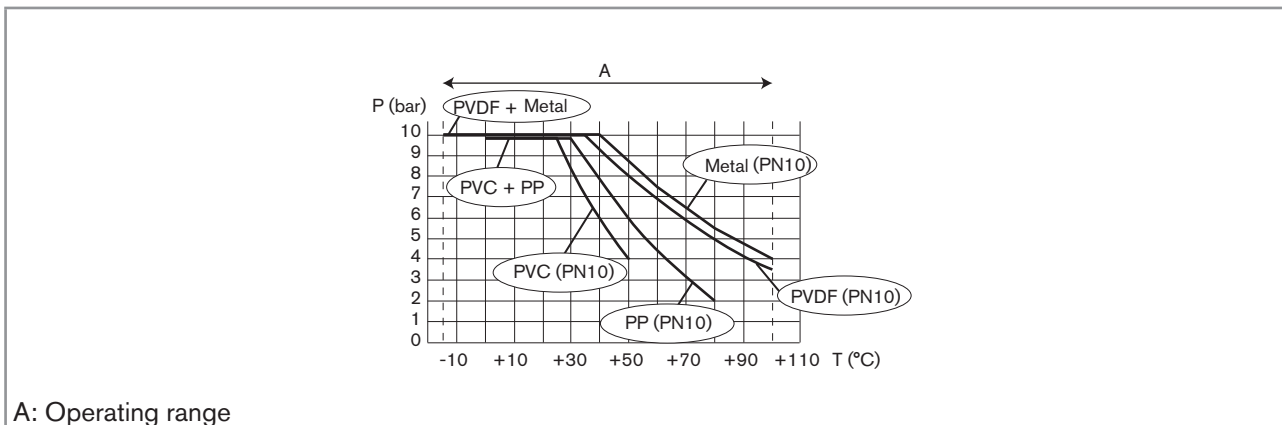

Figure 5 : Fluid temperature-pressure dependency for the flowmeter 8026 associated to a fitting S020

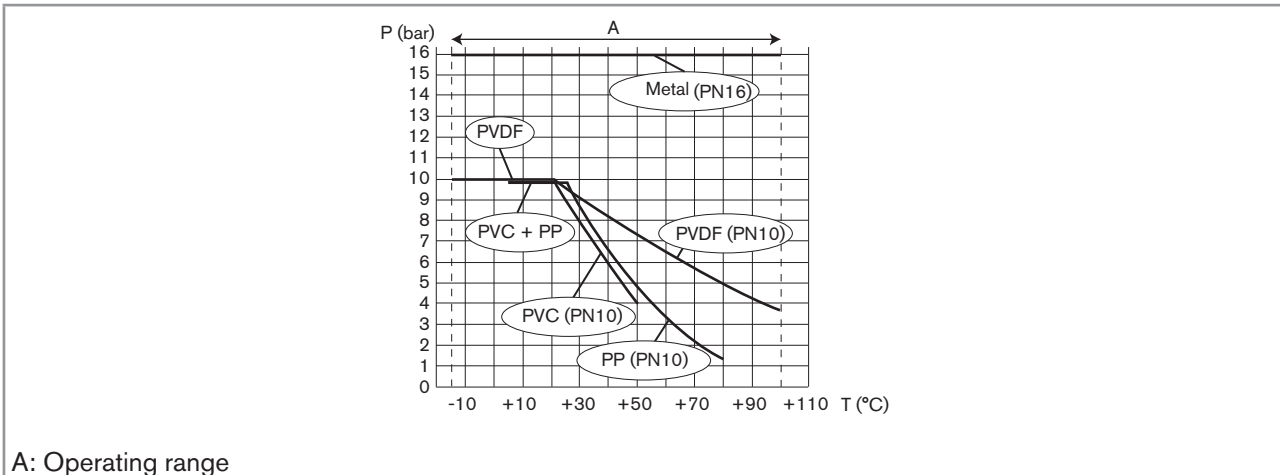

Figure 6 : Fluid temperature-pressure dependency for the flowmeter 8036 (SE36 associated to a fitting S030 with PVDF paddle wheel)

### 6.3.2. General data

|                   |  |
|-------------------|--|
| Pipe diameter     | DN06 to DN400;<br><br>For a fitting S020 or S030 the appropriate diameter is determined using the flow rate / DN / fluid velocity graphs: refer to the operating manuals of the fittings   |
| Type of fitting   | <ul style="list-style-type: none"> <li>▪ S020 for flowmeter 8026: see corresponding operating manual</li> <li>▪ S030 for flowmeter 8036: see corresponding operating manual</li> <li>▪ S070 for flowmeter 8076: see corresponding operating manual</li> </ul>  |
| Fluid temperature | <ul style="list-style-type: none"> <li>▪ 8026                             <ul style="list-style-type: none"> <li>▪ -15 to +100 °C; Also factor in the fluid temperature/pressure dependency for the 8026 inserted into an S020 fitting: see <a href="#">Figure 5</a></li> </ul> </li> <li>▪ 8036 with fitting S030 in PVC <sup>1)</sup> <ul style="list-style-type: none"> <li>▪ 0 to +50 °C; Also factor in the fluid temperature/pressure dependency for the 8036: see <a href="#">Figure 6</a></li> </ul> </li> <li>▪ 8036 with fitting S030 in PP <sup>1)</sup> <ul style="list-style-type: none"> <li>▪ 0 to +80 °C; Also factor in the fluid temperature/pressure dependency for the 8036: see <a href="#">Figure 6</a></li> </ul> </li> <li>▪ 8036 with fitting S030 in PVDF <sup>1)</sup>, brass<sup>1)</sup> or stainless steel <sup>1)</sup> <ul style="list-style-type: none"> <li>▪ -15 to +80 °C; Also factor in the fluid temperature/pressure dependency for the 8036: see <a href="#">Figure 6</a></li> </ul> </li> <li>▪ 8076 with fitting S070 in aluminium                             <ul style="list-style-type: none"> <li>▪ max. +80 °C</li> </ul> </li> <li>▪ 8076 with fitting S070 in stainless steel                             <ul style="list-style-type: none"> <li>▪ max. +100 °C</li> </ul> </li> </ul> |

|  |  |
|--|--|
| <p><b>Fluid pressure</b></p> <ul style="list-style-type: none"> <li>▪ 8026</li> <li>▪ 8036</li> <li>▪ 8076 with a fitting S070 of DN15</li> <li>▪ 8076 with a fitting S070 of DN25</li> <li>▪ 8076 with a fitting S070 of DN40 or DN50</li> <li>▪ 8076 with a fitting S070 of DN80</li> <li>▪ 8076 with a fitting S070 of DN100</li> </ul> | <p>Also refer to the requirements of the Pressure Directive: see chap. <a href="#">6.2.2</a></p> <ul style="list-style-type: none"> <li>▪ PN10; Also factor in the fluid temperature/pressure dependency for the 8026 inserted into an S020 fitting (see <a href="#">Figure 5</a>)</li> <li>▪ PN16; Also factor in the fluid temperature/pressure dependency for the 8036 (SE36 mounted on an S030 fitting): see <a href="#">Figure 6</a></li> <li>▪ max. 55 bar</li> <li>▪ max. 55 bar (or the rules governing the flanges)</li> <li>▪ max. 18 bar</li> <li>▪ max. 12 bar</li> <li>▪ max. 10 bar</li> </ul> |
| <p><b>Type of fluid</b></p> <ul style="list-style-type: none"> <li>▪ 8026 and 8036</li> <li>▪ 8076</li> </ul>  | <ul style="list-style-type: none"> <li>▪ Neutral or slightly aggressive fluids</li> <li>▪ Viscous fluids, free of solid particles</li> </ul>   |
| <p><b>Fluid viscosity</b></p> <ul style="list-style-type: none"> <li>▪ 8026 and 8036</li> <li>▪ 8076</li> </ul>  | <ul style="list-style-type: none"> <li>▪ 300 cSt max.</li> <li>▪ Refer to the operating manual for fitting S070</li> </ul>   |
| <p><b>Solid particle rate in the fluid</b></p> <ul style="list-style-type: none"> <li>▪ 8026 and 8036</li> <li>▪ 8076</li> </ul>   | <ul style="list-style-type: none"> <li>▪ ≤ 1%</li> <li>▪ 0 %</li> </ul>  |
| <p><b>Flow rate measurement</b></p> <ul style="list-style-type: none"> <li>▪ Measurement range</li> <li>▪ Linearity</li> <li>▪ Repeatability</li> <li>▪ Measurement error with standard K factor</li> <li>▪ measurement error with a Teach-in procedure</li> </ul>   | <ul style="list-style-type: none"> <li>▪ 0,3 to 10 m/s</li> <li>▪ ±0,5% <sup>2)</sup> of the full scale</li> <li>▪ ±0,4% <sup>2)</sup> of the measured value</li> <li>▪ ±2,5% <sup>2)</sup> of the measured value</li> <li>▪ ±1% <sup>2)</sup> of the measured value (at the teach-in point)</li> </ul>  |

<sup>1)</sup> and PVDF paddle wheel

<sup>2)</sup> Determined in the following reference conditions: fluid = water, water and ambient temperatures = 20 °C, upstream and downstream distances respected, appropriate pipe dimensions.

### 6.3.3. Electrical data

|  |  |
|--|--|
| <p><b>Power supply</b></p> <ul style="list-style-type: none"> <li>▪ version with 2 or 3 outputs (2 wires)</li> <li>▪ version with 4 outputs (3 wires)</li> </ul> | <ul style="list-style-type: none"> <li>▪ 14-36 V DC, filtered and regulated</li> <li>▪ 12-36 V DC, filtered and regulated</li> </ul> |
|--|--|

|  |  |
|--|--|
| Specifications of the power source (not supplied) of the UL devices  | <ul style="list-style-type: none"> <li>▪ limited energy source (in accordance to UL 61010-1, paragraph 9.3)</li> <li>▪ or Class 2 source (in accordance to standards 1310/1585 and 60950-1)</li> </ul>   |
| Current consumption  | <ul style="list-style-type: none"> <li>▪ version with 2 or 3 outputs (2 wires)     ▪ 25 mA max. (at 14 V DC)</li> <li>▪ version with 4 outputs (3 wires)       ▪ 5 mA max. (at 12 V DC)</li> </ul>   |
| Current consumption, with loads on the transistors   | 1 A max.   |
| Power consumption  | 40 W max.  |
| Protection against polarity reversal   | yes  |
| Protection against voltage spikes  | yes  |
| Protection against short circuits  | yes, transistor outputs  |
| Transistor output  | <ul style="list-style-type: none"> <li>▪ Version with only 1 transistor output     ▪ NPN, open collector, 700 mA max., 1-36 V DC</li> <li>▪ Version with 2 transistor outputs       ▪ NPN (/sink) or PNP (/source) (depending on parameter setting), open collector, 700 mA max., 500 mA max. per transistor if both transistor outputs are wired.<br/>NPN output: 1-36 V DC<br/>PNP output: supply voltage</li> </ul> |
| Current output   | 4-20 mA, sink ("NPN sink") or source ("PNP source") (depending on parameter setting)   |
| <ul style="list-style-type: none"> <li>▪ Version with only 1 current output (2 wires)</li> <li>▪ version with 2 current outputs (3 wires)</li> </ul> | <ul style="list-style-type: none"> <li>▪ max. loop impedance: 1100 Ω at 36 V DC, 610 Ω at 24 V DC, 180 Ω at 14 V DC</li> <li>▪ max. loop impedance: 1100 Ω at 36 V DC, 610 Ω at 24 V DC, 100 Ω at 12 V DC</li> </ul>   |

MAN 1000182212 EN Version: A Status: RL (released | freigegeben) printed: 19.01.2015

## 7. ASSEMBLY

### 7.1. Safety instructions

**⚠ DANGER**

**Risk of injury due to electrical voltage.**

- Shut down and isolate the electrical power source before carrying out work on the system.
- Observe all applicable accident protection and safety regulations for electrical equipment.

**⚠ WARNING**

**Risk of injury due to non-conforming assembly.**

- The device must only be assembled by qualified and skilled staff with the appropriate tools.

**Risk of injury due to unintentional switch on of power supply or uncontrolled restarting of the installation.**

- Take appropriate measures to avoid unintentional activation of the installation.
- Guarantee a set or controlled restarting of the process subsequent to any intervention on the device.

### 7.2. Unscrewing the cover

**NOTE**

**The tightness of the device is not guaranteed when the cover is removed.**

- Once the cover is removed, prevent the projection of liquid inside the housing.

**The device may be damaged if a metal component comes into contact with the electronics.**

- Prevent contact of the electronics with a metal component (screwdriver, for example).

|  |  |
|--|--|
|  | <p>→ To unscrew the cover, use your hand or a tool which can be used as a lever, taking care not to scratch the glass.</p> |
|  | <p>→ Turn the cover until fully unscrewed.</p>   |

Figure 7 : Unscrewing the cover

### 7.3. Mounting the cover

|   |  |
|---|--|
|  | <ul style="list-style-type: none"> <li>→ Check that there is a seal on the cover and that it is not damaged. Replace it if necessary.</li> <li>→ Grease the seal if necessary, using a component compatible with the seal material.</li> </ul> |
|  | <ul style="list-style-type: none"> <li>→ Fully tighten by hand to guarantee tightness.</li> </ul>  |

Figure 8 : Fitting the cover

### 7.4. Mounting the display module

|   |  |
|---|--|
|  | <ul style="list-style-type: none"> <li>→ Unscrew the cover (see chapter <a href="#">7.2</a>).</li> <li>→ Set the display module at an angle of ca. 20° in relation to the desired position.</li> </ul> |
|  | <ul style="list-style-type: none"> <li>→ The module can be mounted in 4 different positions, at 90° intervals.</li> </ul>  |
|  | <ul style="list-style-type: none"> <li>→ Fully push in the module and turn to the right to lock it.</li> </ul>   |

Figure 9 : Mounting the display module

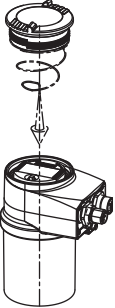
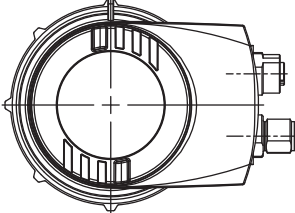

## 7.5. Dismounting the display module

|  |  |
|--|--|
|   | <p>→ Unscrew the cover if necessary (see chapter <a href="#">7.2</a>).</p> <p>→ Turn the module by ca. 20° to the left. Once unlocked, the module is raised slightly by the spring action.</p> |
|  | <p>→ Remove the module from its housing.</p>   |

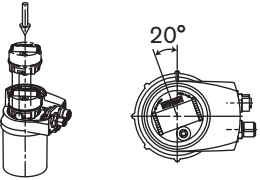
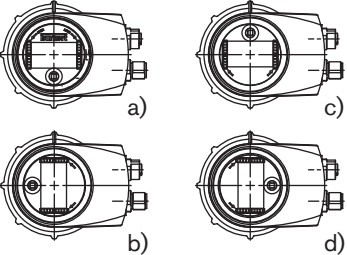
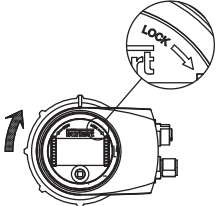
Figure 10 : Dismounting the display module

## 8. INSTALLATION AND WIRING

### 8.1. Safety instructions

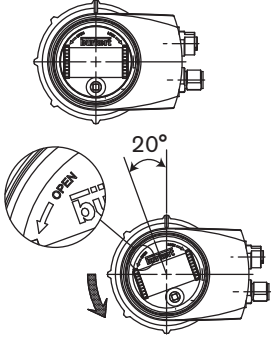
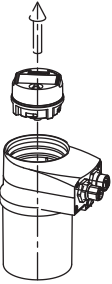

#### **DANGER**

##### **Risk of injury due to high pressure in the installation.**

- Stop the circulation of fluid, cut off the pressure and drain the pipe before loosening the process connections.

##### **Risk of injury due to electrical voltage.**

- Shut down and isolate the electrical power source before carrying out work on the system.
- Observe all applicable accident protection and safety regulations for electrical equipment.

##### **Risk of injury due to the nature of the fluid.**

- Respect the prevailing regulations on accident prevention and safety relating to the use of aggressive fluids.



#### **WARNING**

##### **Risk of injury due to non-conforming installation.**

- The electrical and fluid installation can only be carried out by qualified and skilled staff with the appropriate tools.
- Install appropriate safety devices (correctly rated fuse and/or circuit-breaker).
- Respect the assembly instructions for the fitting used.

##### **Risk of injury due to unintentional switch on of power supply or uncontrolled restarting of the installation.**

- Take appropriate measures to avoid unintentional activation of the installation.
- Guarantee a set or controlled restarting of the process subsequent to any intervention on the device.

### 8.2. Installation onto the pipe



#### **DANGER**

##### **Risk of injury due to high pressure in the installation.**

- Stop the circulation of fluid, cut off the pressure and drain the pipe before loosening the process connections.

##### **Risk of injury due to the nature of the fluid.**

- Respect the prevailing regulations on accident prevention and safety relating to the use of aggressive fluids.

### 8.2.1. Recommendations on installing an 8026 or an 8036 on a pipe



#### ATTENTION

Risk of damage when installing the fitting.

- Respect the installation instructions given in the user manual for the fitting.

→ Install the fitting on the pipe, respecting the instructions given in the manual for the fitting used.

→ Respect the following additional conditions of installation to ensure that the device operates correctly (Figure 11 and Figure 12).

- Install the device in such a way that the paddle wheel axis is horizontal.
- Prevent the formation of air bubbles in the pipe in the section around the sensor.
- Ensure that the pipe is always filled in the section around the sensor.

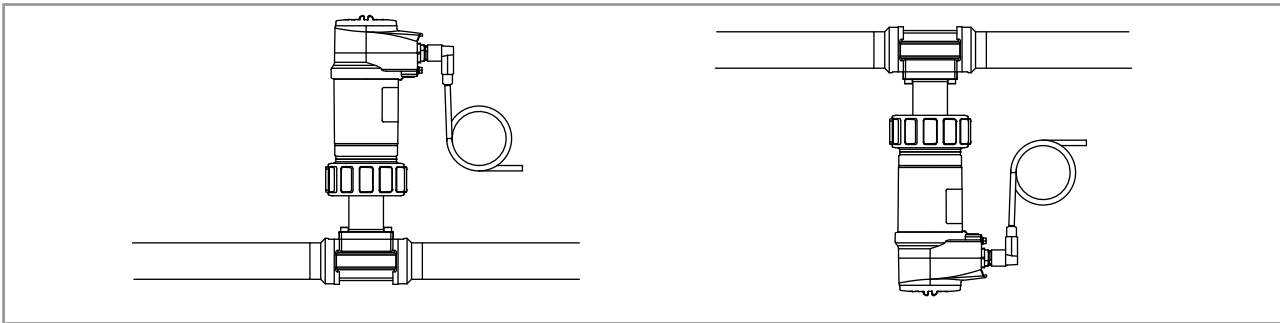

Figure 11 : The paddle wheel axis must be horizontal

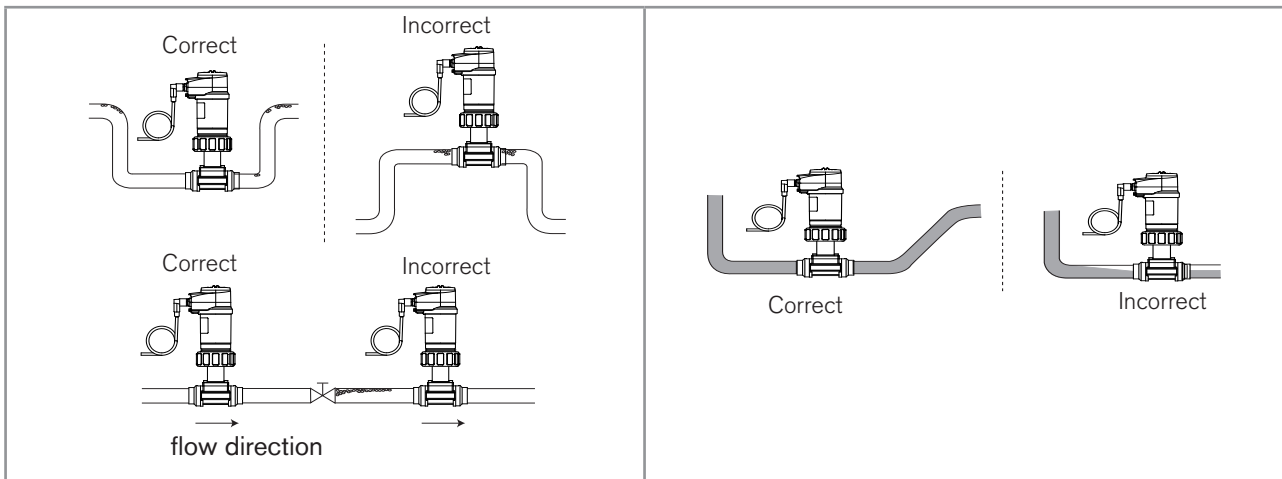
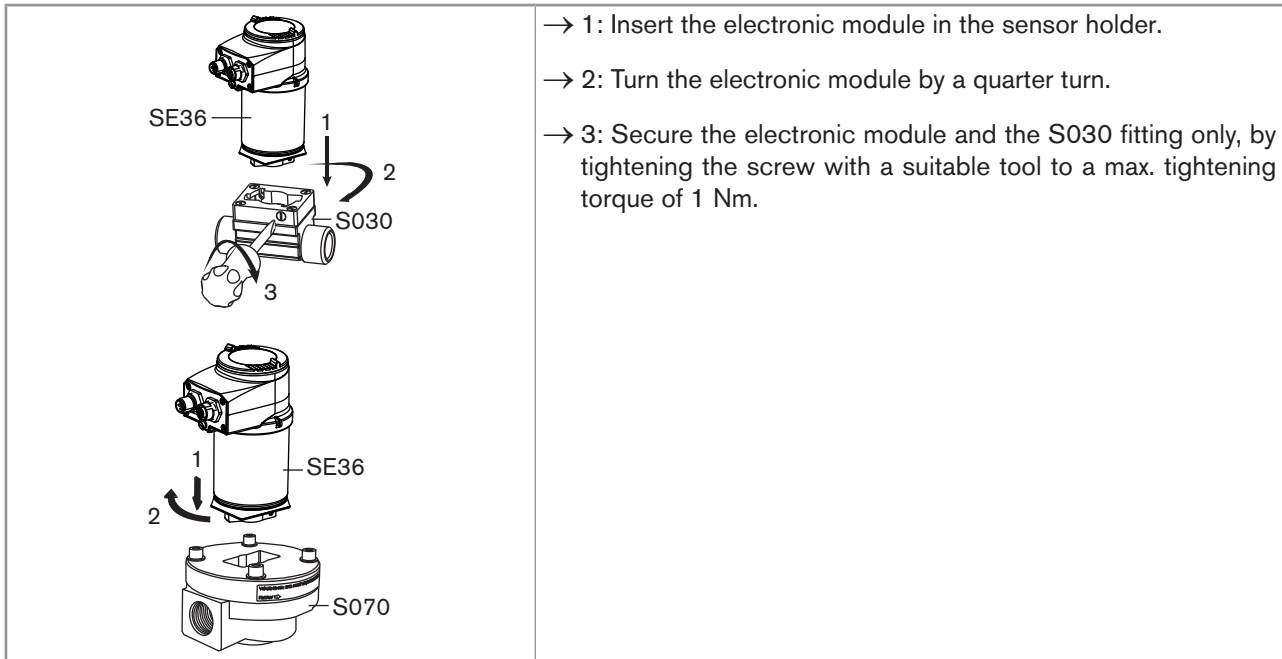

Figure 12 : Air bubbles within the pipe / Filling of the pipe

→ Fit the display module (see chap. 7.4) to parameter the device.

→ Assemble the flowmeter 8036 (see Figure 13) or install the flowmeter 8026 into the fitting S020 (see Figure 14)



- 1: Insert the electronic module in the sensor holder.
- 2: Turn the electronic module by a quarter turn.
- 3: Secure the electronic module and the S030 fitting only, by tightening the screw with a suitable tool to a max. tightening torque of 1 Nm.

Figure 13 : Assembling the SE36 and the fitting S030 or S070

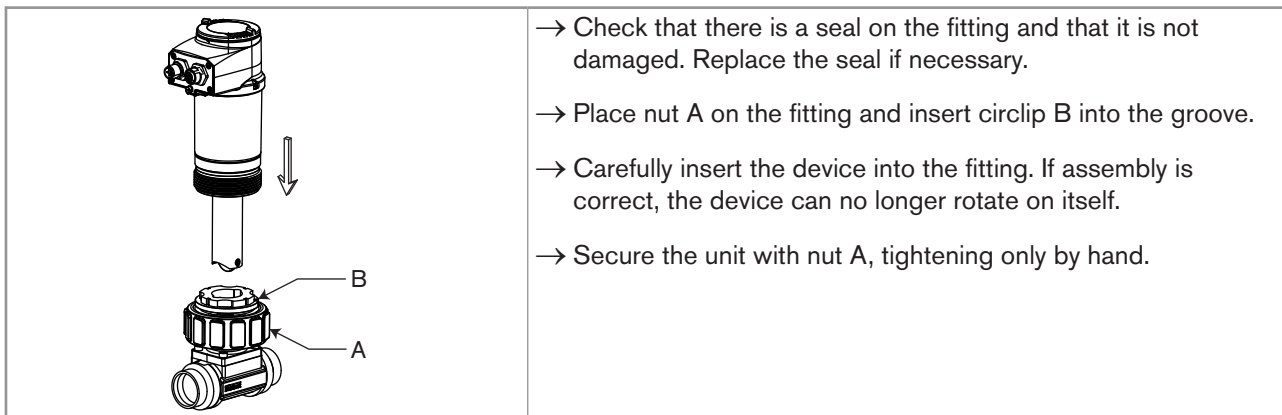

- Check that there is a seal on the fitting and that it is not damaged. Replace the seal if necessary.
- Place nut A on the fitting and insert circlip B into the groove.
- Carefully insert the device into the fitting. If assembly is correct, the device can no longer rotate on itself.
- Secure the unit with nut A, tightening only by hand.

Figure 14 : Installation of flowmeter 8026 into the fitting S020

- Set the K factor parameter (see chap. 9.13.5) or have it determined through a teach-in procedure.

### 8.2.2. Recommendations on installing an 8076 on a pipe

- Install the fitting S070 on the pipe in such a way that the oval gear axes are in the horizontal plane, as shown in [Figure 15](#).

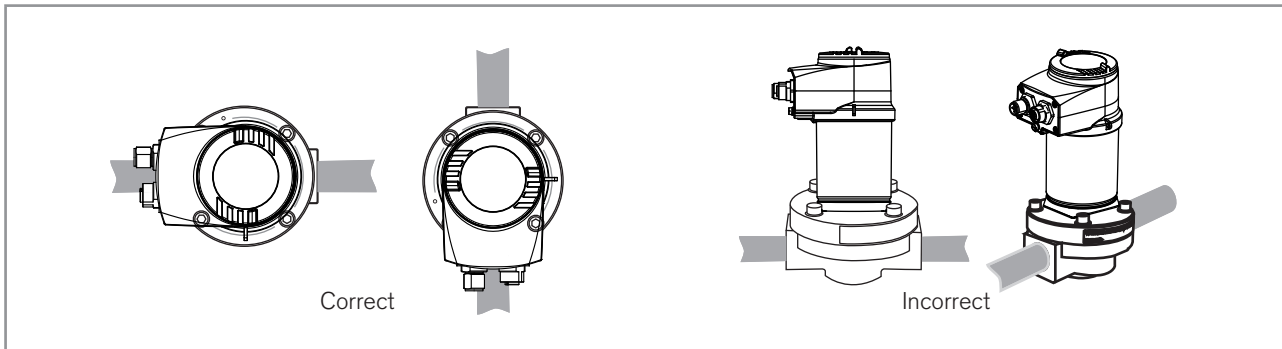

Figure 15 : The oval gear axes must be horizontal (seen from the front)

- Fit the display module (see chap. 7.4) to parameter the device.
- Assemble flowmeter type 8076 (see Figure 13)
- Set the K factor parameter (see chap. 9.13.5) or have it determined through a teach-in procedure.

### 8.3. Wiring



#### DANGER

Risk of injury due to electrical voltage.

- Shut down and isolate the electrical power source before carrying out work on the system.
- Observe all applicable accident protection and safety regulations for electrical equipment.



- Use a high quality electrical power supply (filtered and regulated).
- Make sure the installation is equipotential. See chap. 8.3.3.
- Use a shielded cable.
- Once the device is wired, set the "HWMoDe" parameter depending on the wiring carried out, sink/NPN or source/PNP. See chap. 9.12.8.

#### 8.3.1. Electrical connections

| Number of fixed connectors                                  | Type of connectors  |
|---|---|
| 1 male M12 fixed connector                                  | female 5-pin M12 (available as an accessory: see chap. 11)                      |
| 1 male M12 fixed connector and 1 female M12 fixed connector | female 5-pin M12 + male 5-pin M12 (both available as accessories: see chap. 11) |

#### 8.3.2. Assembling the male or female connector (accessories:

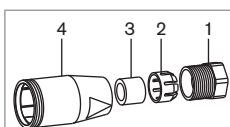

- Unscrew the nut [1] on the body [4].
- Insert the cable into the nut [1], the cable clamp [2] and the seal [3], and then into the body [4].

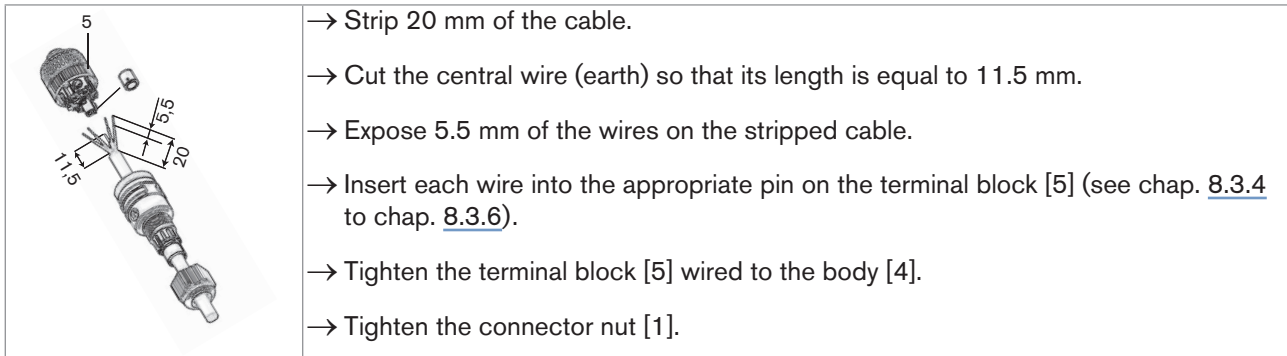

Figure 16 : Multipin M12 connector (available as an accessory)

### 8.3.3. Equipotentiality of the installation

To ensure the equipotentiality of the installation (power supply - device - fluid):

- Connect together the various earth spots in the installation to eliminate the potential differences that may occur between different earthes.
- Observe faultless grounding of the shield of the power supply cable.
- Special attention has to be paid if the device is installed on plastic pipes because there is no direct earthing possible. Proper earthing is performed by earthing together the metallic devices such as pumps or valves, that are as close as possible to the device.

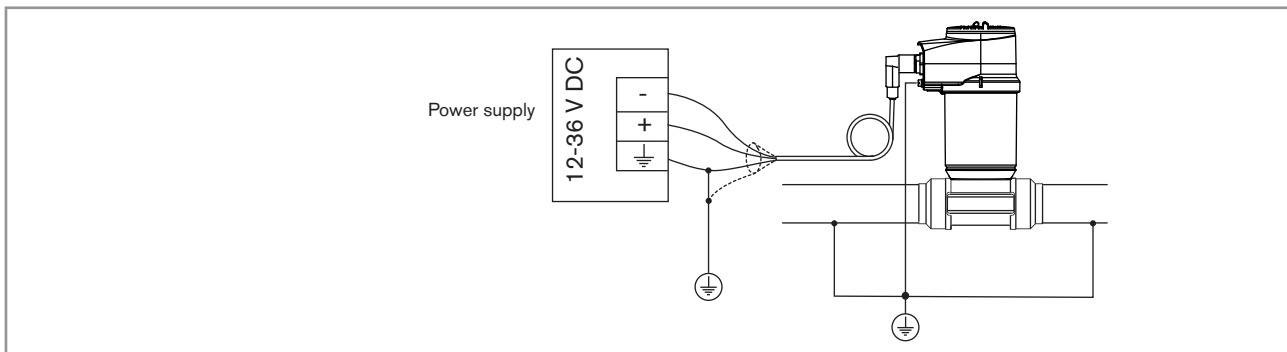

Figure 17 : Equipotentiality skeleton diagram with pipes in metal

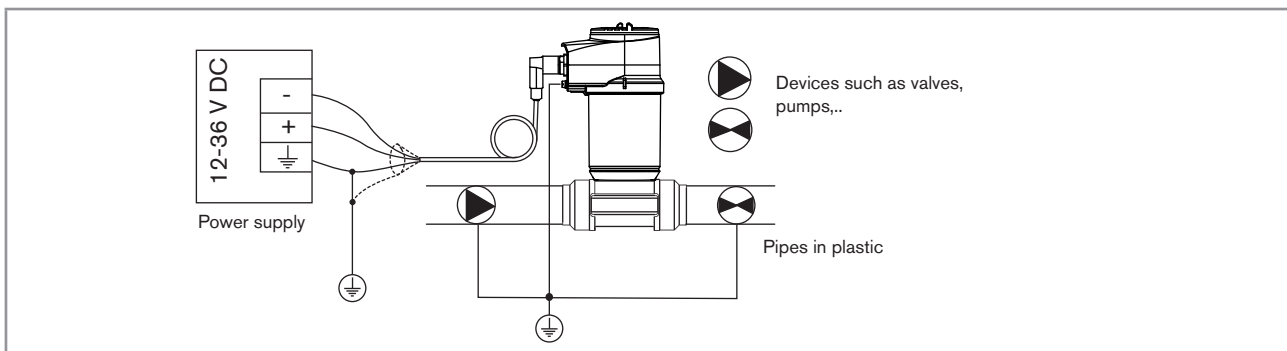

Figure 18 : Equipotentiality skeleton diagram with pipes in plastic

### 8.3.4. Wiring a version with a single M12 fixed connector and an NPN transistor output and a current output

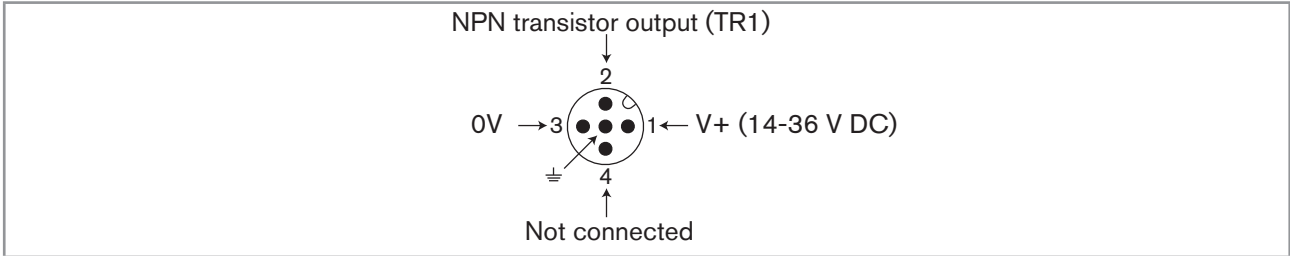

Figure 19 : Pin assignment of the male fixed connector on a version with 1 NPN transistor output and 1 current output

| Pin of the female M12 connector available as an accessory (order code 438680) | Colour of the wire |
|---|--------------------|
| 1   | brown              |
| 2   | white              |
| 3   | blue               |
| 4   | black              |
| 5   | grey               |

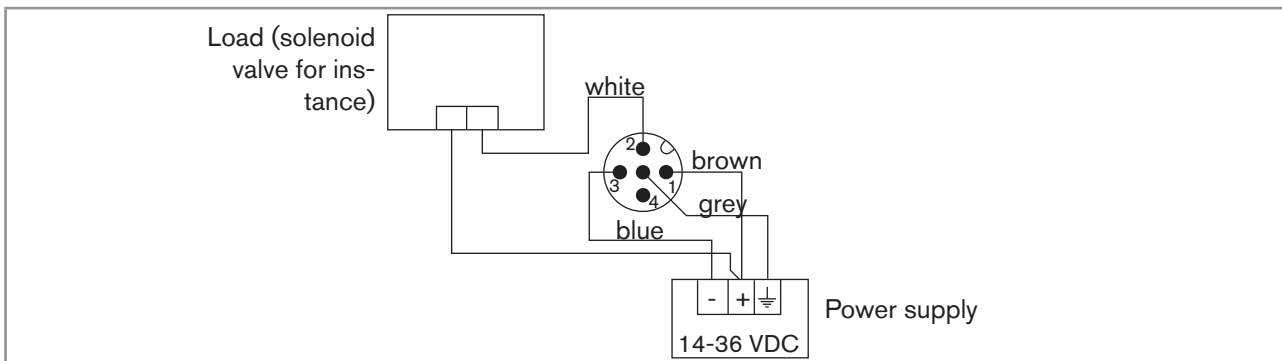

Figure 20 : Wiring the NPN transistor output (parameter setting "NPN/sink", cannot be changed), of a version with 1 M12 fixed connector, 1 NPN transistor output and 1 current output

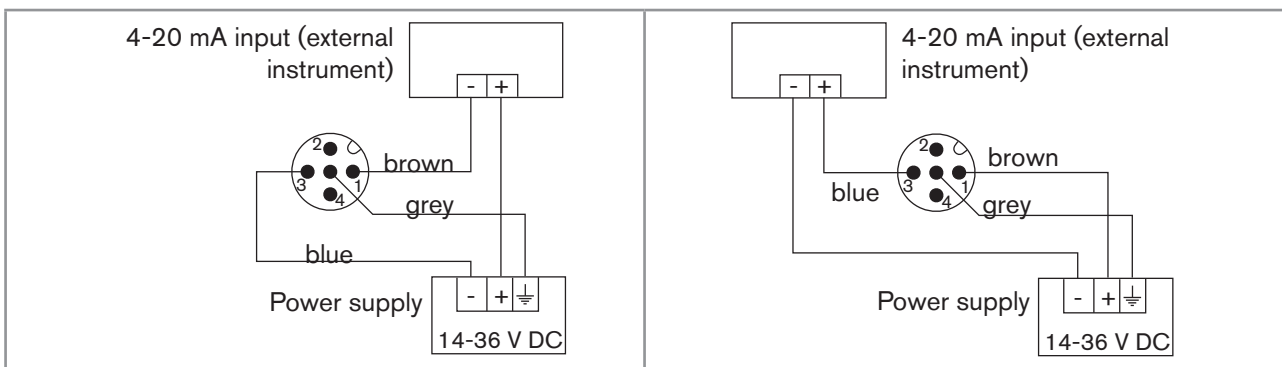

Figure 21 : Possible electrical connections of the current output only, on a version with 1 M12 fixed connector, 1 NPN transistor output and 1 current output

MAN 1000182212 EN Version: A Status: RL (released | freigegeben) printed: 19.01.2015

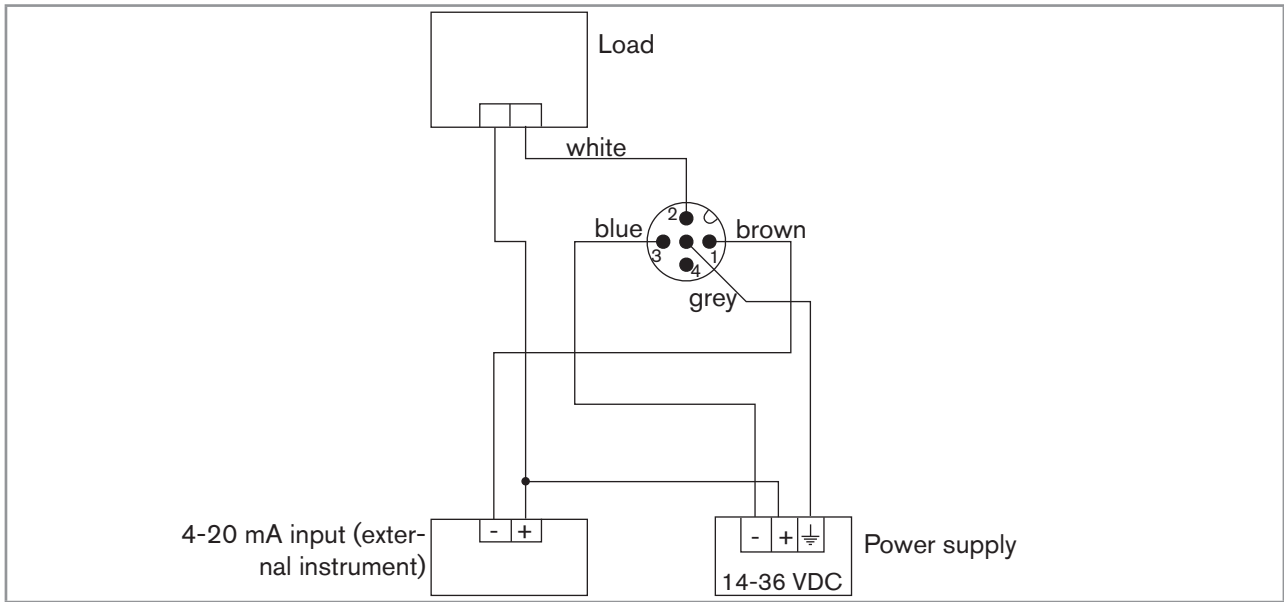

Figure 22 : Wiring the NPN transistor output and the current output in sinking mode (parameter setting "NPN/sink", cannot be changed), on a version with 1 M12 fixed connector, 1 NPN transistor output and 1 current output

### 8.3.5. Wiring a version with a single M12 fixed connector and two transistor outputs and one current output

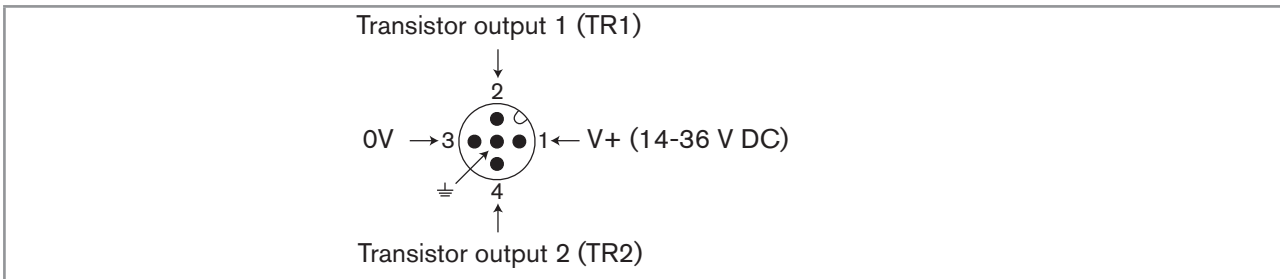

Figure 23 : Pin assignment of the male fixed connector on a version with 2 transistor outputs and 1 current output

| Pin of the female M12 connector available as an accessory (order code 438680) | Colour of the wire |
|---|--------------------|
| 1   | brown              |
| 2   | white              |
| 3   | blue               |
| 4   | black              |
| 5   | grey               |



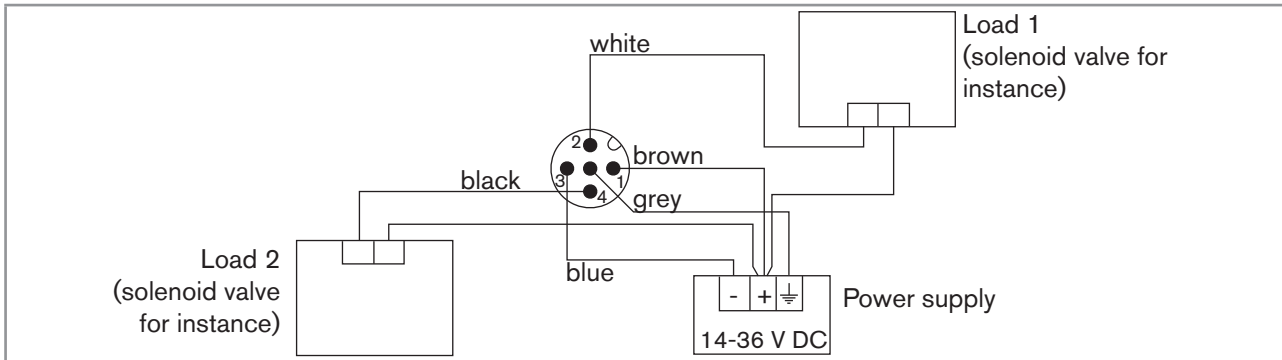

Figure 24 : NPN wiring of both transistor outputs (parameter setting "NPN/sink"), of a version with 1 M12 fixed connector

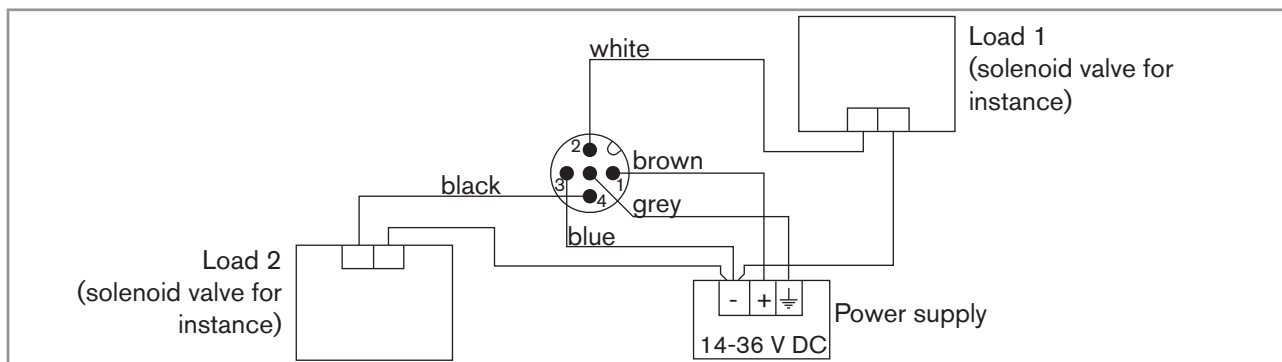

Figure 25 : PNP wiring of both transistor outputs (parameter setting "PNP/source"), of a version with 1 M12 fixed connector

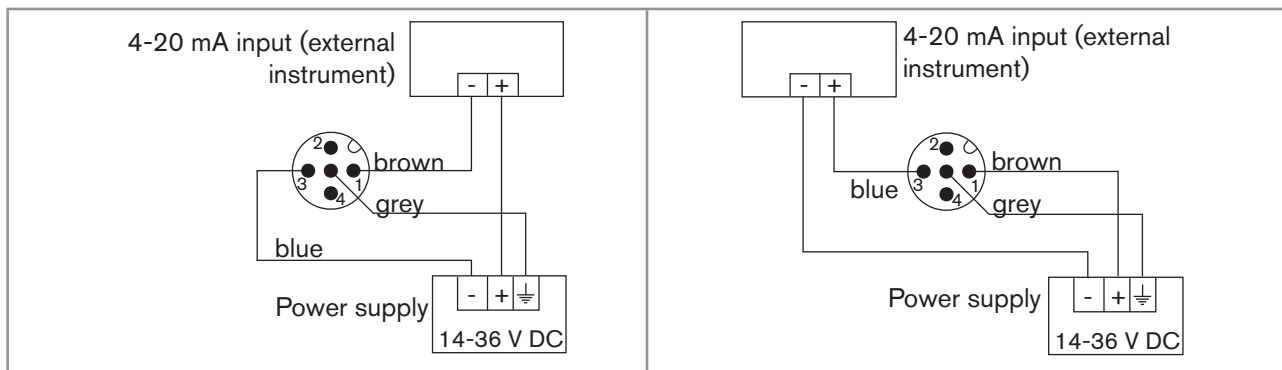

Figure 26 : Possible electrical connections of the current output only (whatever the parameter setting, "NPN/sink" or "PNP/source"), on a version with 1 M12 fixed connector

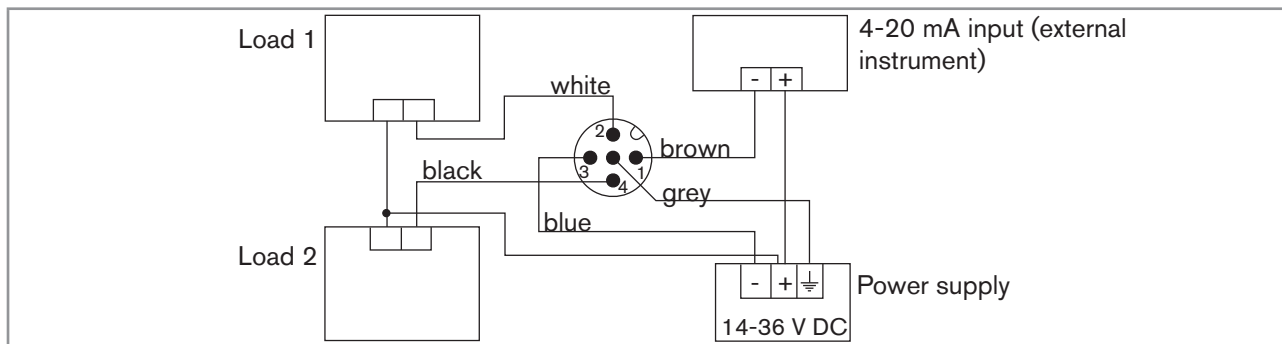

Figure 27 : NPN wiring of both transistor outputs and wiring the current output in sinking mode (parameter setting "NPN/sink"), of a version with 1 M12 fixed connector

MAN 1000182212 EN Version: A Status: RL (released | freigegeben) printed: 19.01.2015

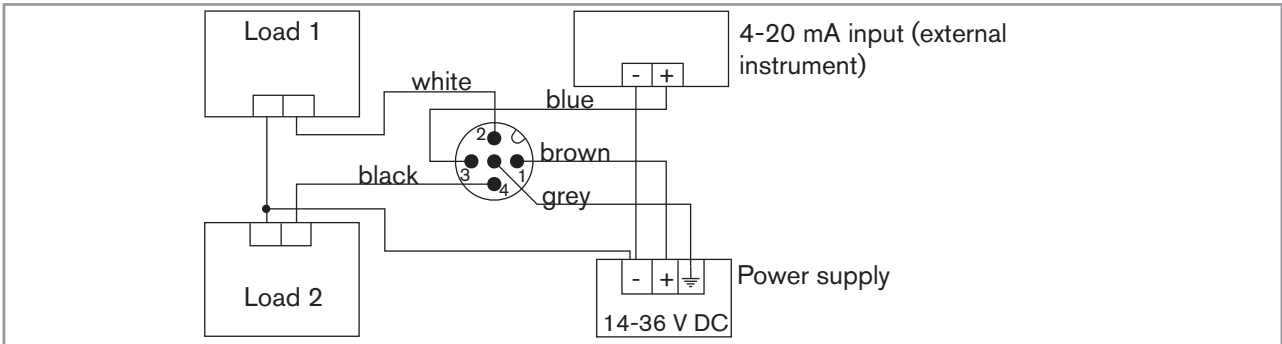

Figure 28 : PNP wiring of both transistor outputs and wiring the current output in sourcing mode (parameter setting "PNP/ source"), of a version with 1 M12 fixed connector

### 8.3.6. Wiring a version with two M12 fixed connectors and two transistor outputs and two current outputs

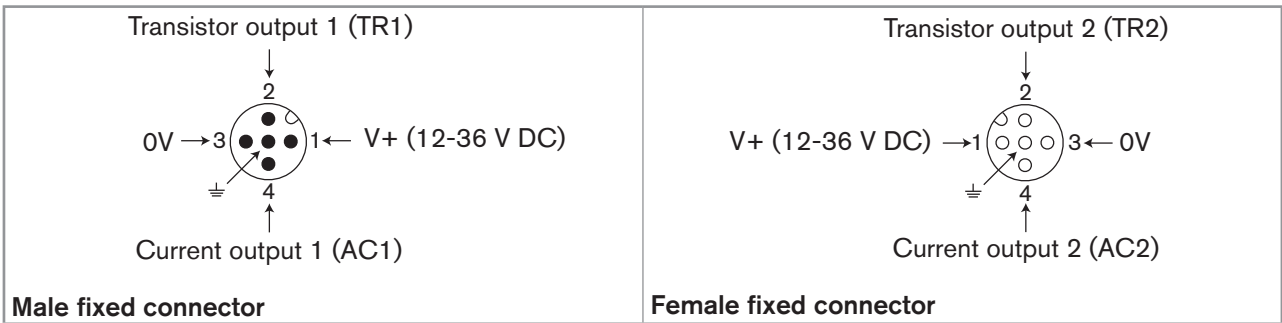

Figure 29 : Pin assignment of the male and female M12 fixed connectors

**!** Connect the power supply for the device to the male fixed connector; the supply is then transferred internally to pins 1 and 3 of the female fixed connector in order to ease wiring of the load to the female fixed connector.

| Pin of the female respectively male M12 cables available as accessories (order code 438680 respectively 559177) | Colour of the wire |
|---|--------------------|
| 1   | brown              |
| 2   | white              |
| 3   | blue               |
| 4   | black              |
| 5   | grey               |

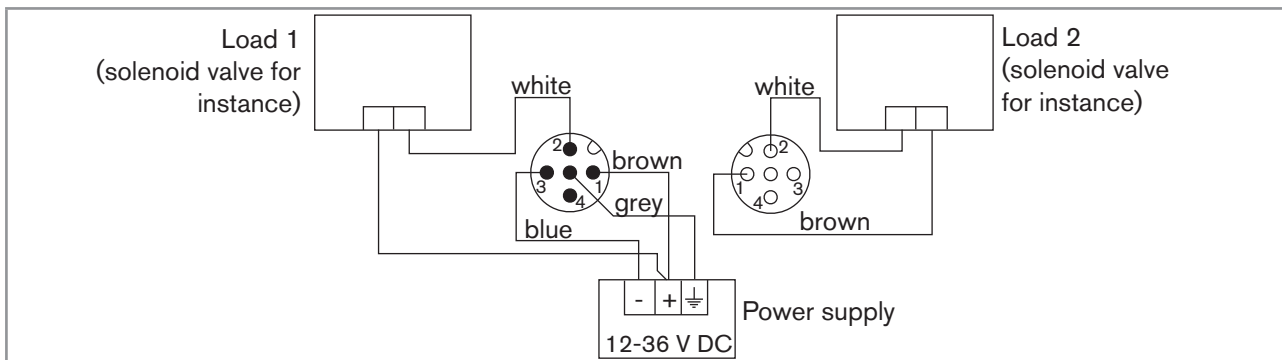

Figure 30 : NPN wiring of both transistor outputs (parameter setting "NPN/sink"), of a version with 2 M12 fixed connectors

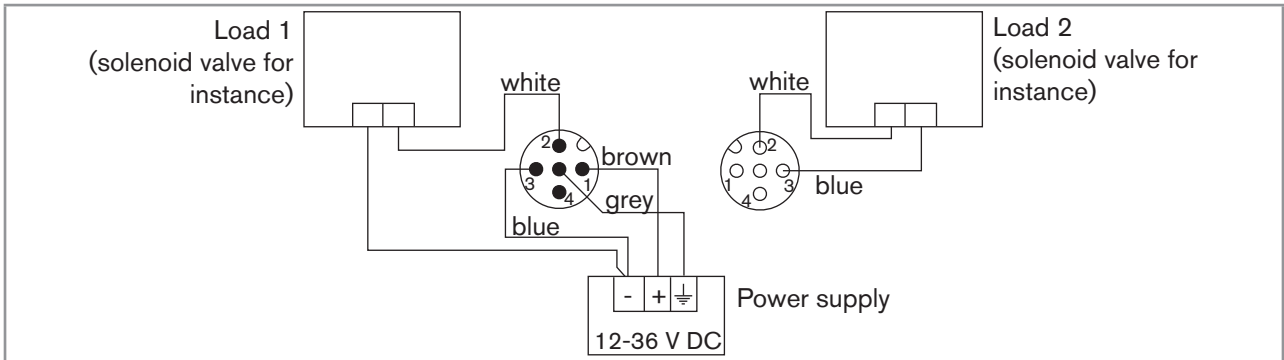

Figure 31 : PNP wiring of both transistor outputs (parameter setting "PNP/source"), of a version with 2 M12 fixed connectors

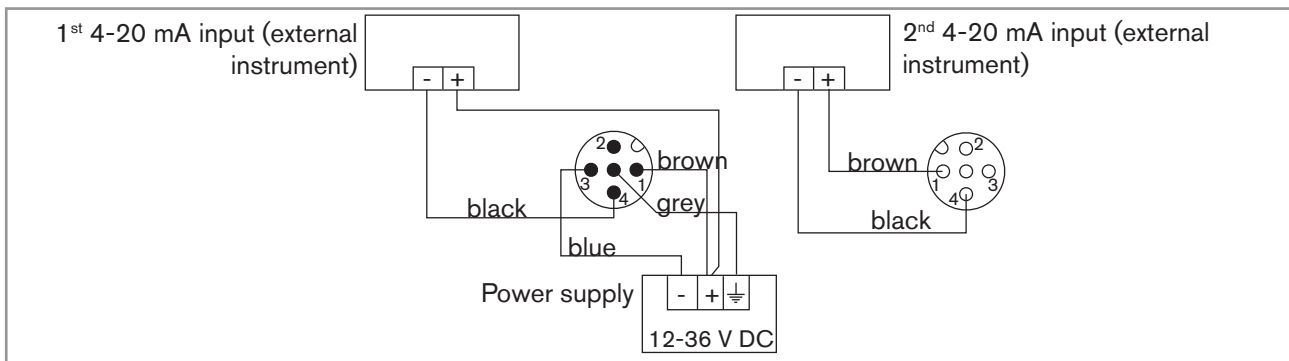

Figure 32 : Wiring of both current outputs in sinking mode, on a version with 2 fixed connectors (parameter setting "NPN/sink")

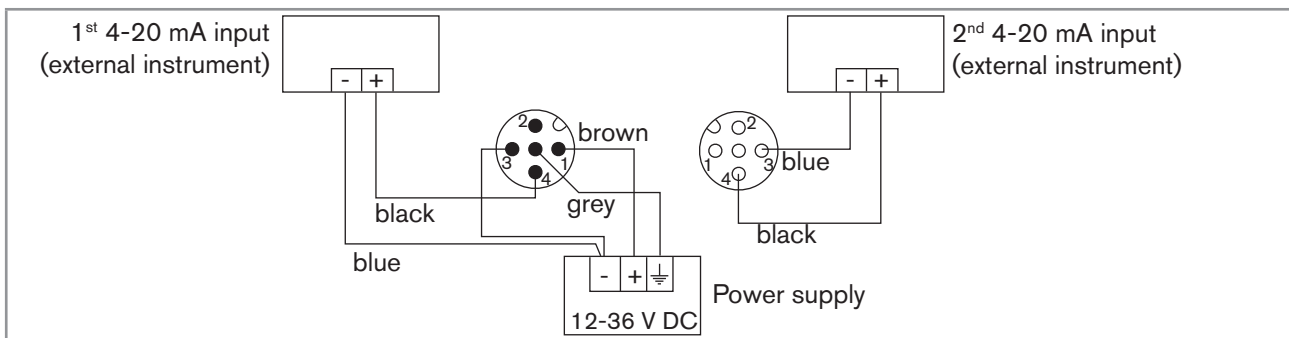

Figure 33 : Wiring of both current outputs in sourcing mode, on a version with 2 fixed connectors (parameter setting "PNP/source")

MAN 1000182212 EN Version: A Status: RL (released | freigegeben) printed: 19.01.2015

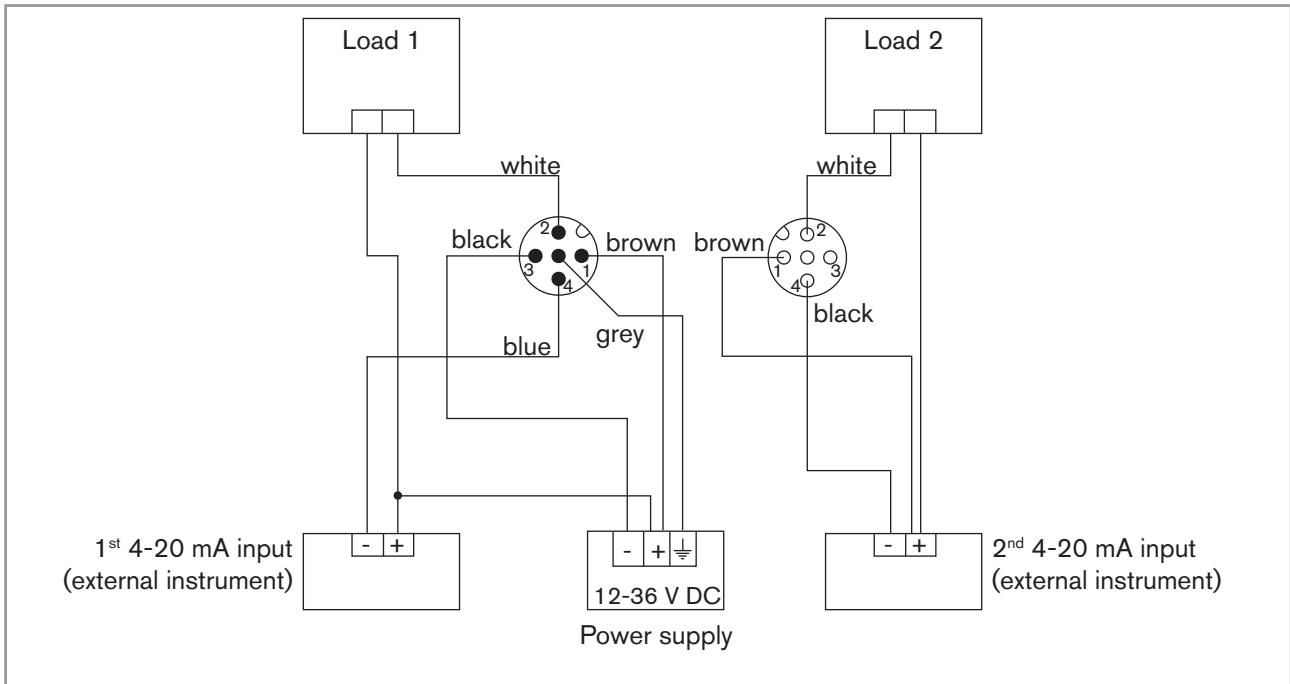

Figure 34 : NPN wiring of both transistor outputs and wiring of both current outputs in sinking mode, on a version with 2 fixed connectors (parameter setting "NPN/sink")

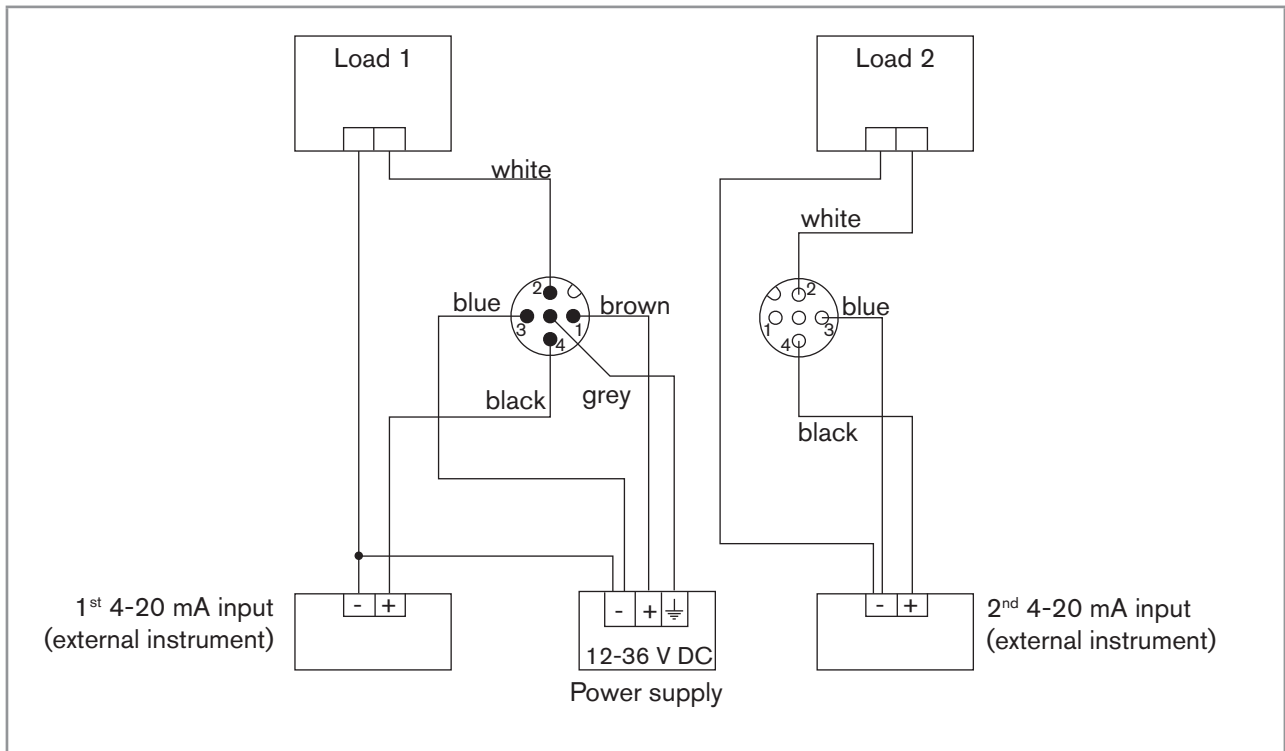

Figure 35 : PNP wiring of both transistor outputs and wiring of both current outputs in sourcing mode, on a version with 2 fixed connectors (parameter setting "PNP/source")

MAN 1000182212 EN Version: A Status: RL (released | freigegeben) printed: 19.01.2015

## 9. ADJUSTMENT AND COMMISSIONING

### 9.1. Safety instructions

#### WARNING

##### Risk of injury due to non-conforming adjustment.

Non-conforming operating could lead to injuries and damage the device and its surroundings.

- The operators in charge of adjustment must have read and understood the contents of this manual.
- In particular, observe the safety recommendations and intended use.
- The device/installation must only be adjusted by suitably trained staff.

#### WARNING

##### Danger due to nonconforming commissioning.

Nonconforming commissioning could lead to injuries and damage the device and its surroundings.

- Before commissioning, make sure that the staff in charge have read and fully understood the contents of the manual.
- In particular, observe the safety recommendations and intended use.
- The device / the installation must only be commissioned by suitably trained staff.

#### Protect this device against electromagnetic interference, ultraviolet rays and, when installed outdoors, the effects of the climatic conditions.

### 9.2. When switching on the device

When the device is switched on or the display module mounted on the electronic module, the display indicates the software version of the display. The display then shows the first screen of the Process level:

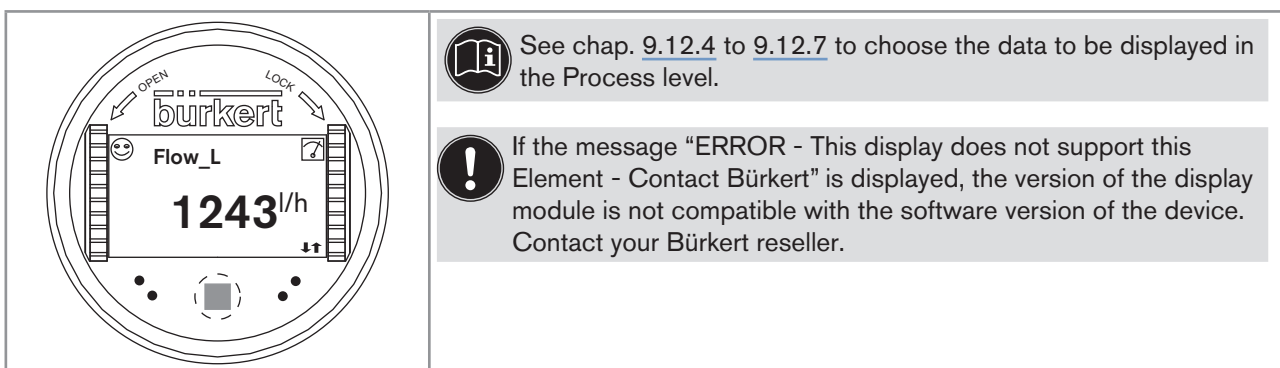

Figure 36 : Display indications when powering on the device

## 9.3. Operating levels

The device has 2 operating levels:





### Process level

This level is used:

- to read the value of the measured flow rate and/or the sensor input frequency
- to read the values of both volume totalizers
- to reset totalizer 2
- to read both the lowest and highest values of the flow rate or the input frequency that have been measured by the device since the latest reset (this feature is not active by default),
- to reset both the lowest and highest values of the flow rate or the input frequency, if the feature has been activated
- to read the current values emitted on the 4-20 mA outputs.

### Configuration level

This level comprises 5 menus:

| Menu title                                   | Relevant icon   |
|--|---|
| "Param": see chap. <a href="#">9.12</a>      |  |
| "Calib": see chap. <a href="#">9.13</a>      |  |
| "Diagnostic": see chap. <a href="#">9.14</a> |  |
| "Test": see chap. <a href="#">9.15</a>       |  |
| "Info": see chap. <a href="#">9.16</a>       |  |

## 9.4. Using the navigation button

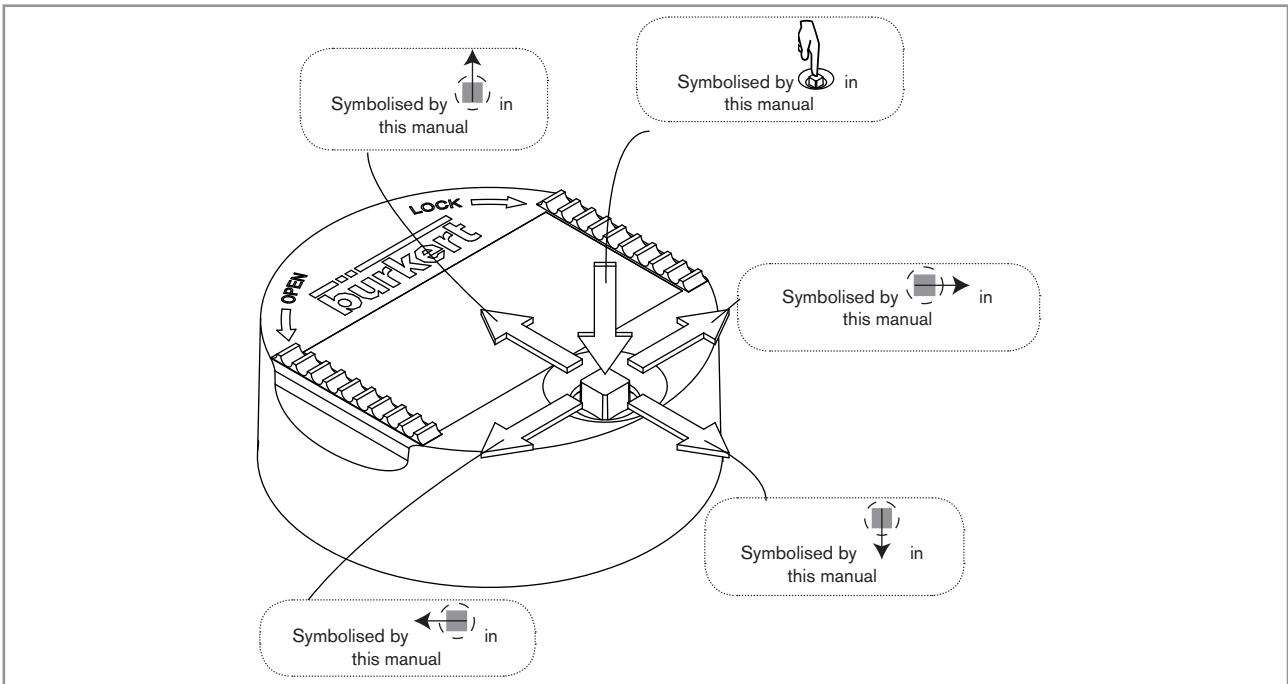













Figure 37 : Using the navigation button

| You want to...   | Press...   |
|--|--|
| ...browse in Read level  | <ul style="list-style-type: none"> <li>next screen: </li> <li>previous screen: </li> </ul>     |
| <ul style="list-style-type: none"> <li>...access the Configuration level</li> <li>...display the Param menu</li> </ul> | for at least 2 sec., from any screen of the Read level   |
| ...browse in the menus of the Configuration level  | <ul style="list-style-type: none"> <li>next menu: </li> <li>previous menu: </li> </ul>         |
| ...access the menu displayed   |  |
| ...browse in the menu functions  | <ul style="list-style-type: none"> <li>next function: </li> <li>previous function: </li> </ul> |
| ...select the highlighted function   |  |

MAN 1000182212 EN Version: A Status: RL (released | freigegeben) printed: 19.01.2015

| You want to...  | Press...   |
|---|--|
| ...browse in the dynamic functions bar (MEAS, BACK, ABORT, OK, YES, NO) | <ul style="list-style-type: none"> <li>▪ next function: </li> <li>▪ previous function: </li> </ul>      |
| ...confirm the highlighted dynamic function                             |   |
| ...modify a numerical value   |  |
| - increment the figure selected   | -   |
| - decrement the figure selected   | -   |
| - select the previous figure  | -   |
| - select the next figure  | -   |
| - allocate the "+" or "-" sign to the numerical value                   | -  to the extreme left of the numerical value<br>then  until the desired sign is displayed                 |
| - move the decimal point  | -  to the extreme right of the numerical value<br>then  until the decimal point is in the desired place |

## 9.5. Using the dynamic functions

| You want to...  | Choose...                      |
|---|--------------------------------|
| ...go back to the READ level, without validating the modifications made | dynamic function "MEAS"        |
| ...confirm the entering   | dynamic function "OK"          |
| ...go back to the parent menu   | dynamic function "BACK"        |
| ...abort the current operation and go back to the parent menu           | dynamic function "ABORT"       |
| ...answer the question asked  | dynamic function "YES" or "NO" |



## 9.6. Example for the input of a numerical value

Modify each digit of the numerical value using:

- to increase the digit selected,
- to decrease the digit selected.

After confirming the numerical value entering, modify the time unit using or .

Select the digit at the extreme right of the numerical value with then move the decimal point with .

Dynamic functions (accessible through and ): see chap. 9.5

## 9.7. Example for browsing in a menu

The icon identifies the current menu

Title of the current menu, sub-menu or function.

Highlighted function

The arrow indicates that some more functions are available which can be displayed by using

The arrow indicates that some more functions are available which can be displayed by using

Dynamic functions (accessible through and ): see chap. 9.5

## 9.8. Description of icons and LEDs

-  The LEDs of the display module are duplicated on the electronic board that is located under the display module: these LEDs become visible when the device is not equipped with the display module.
- The yellow LED related to a transistor output is deactivated if the transistor output is configured in pulse mode ("Pulse").

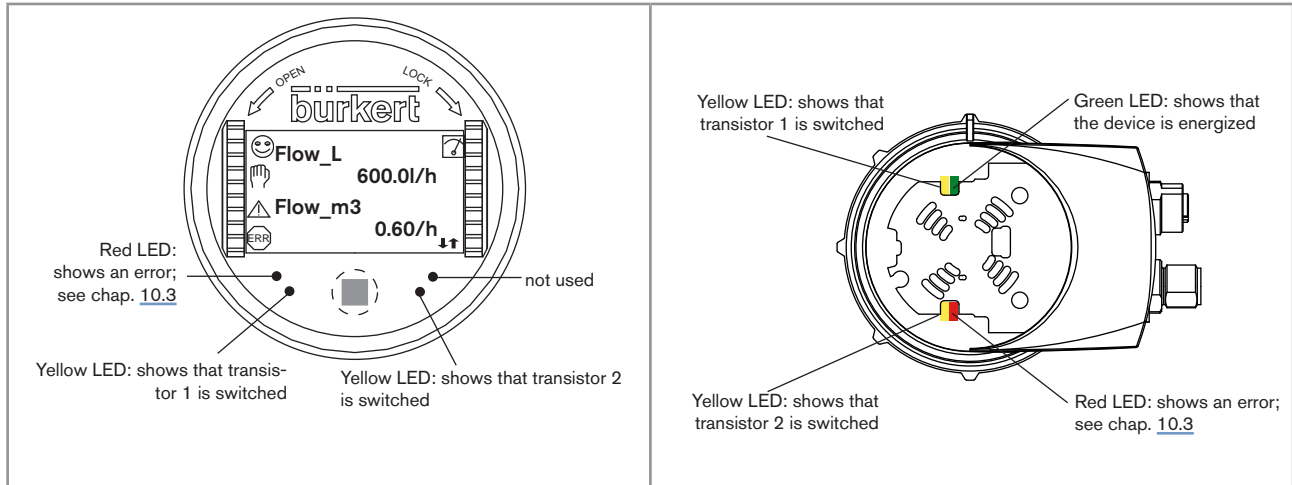









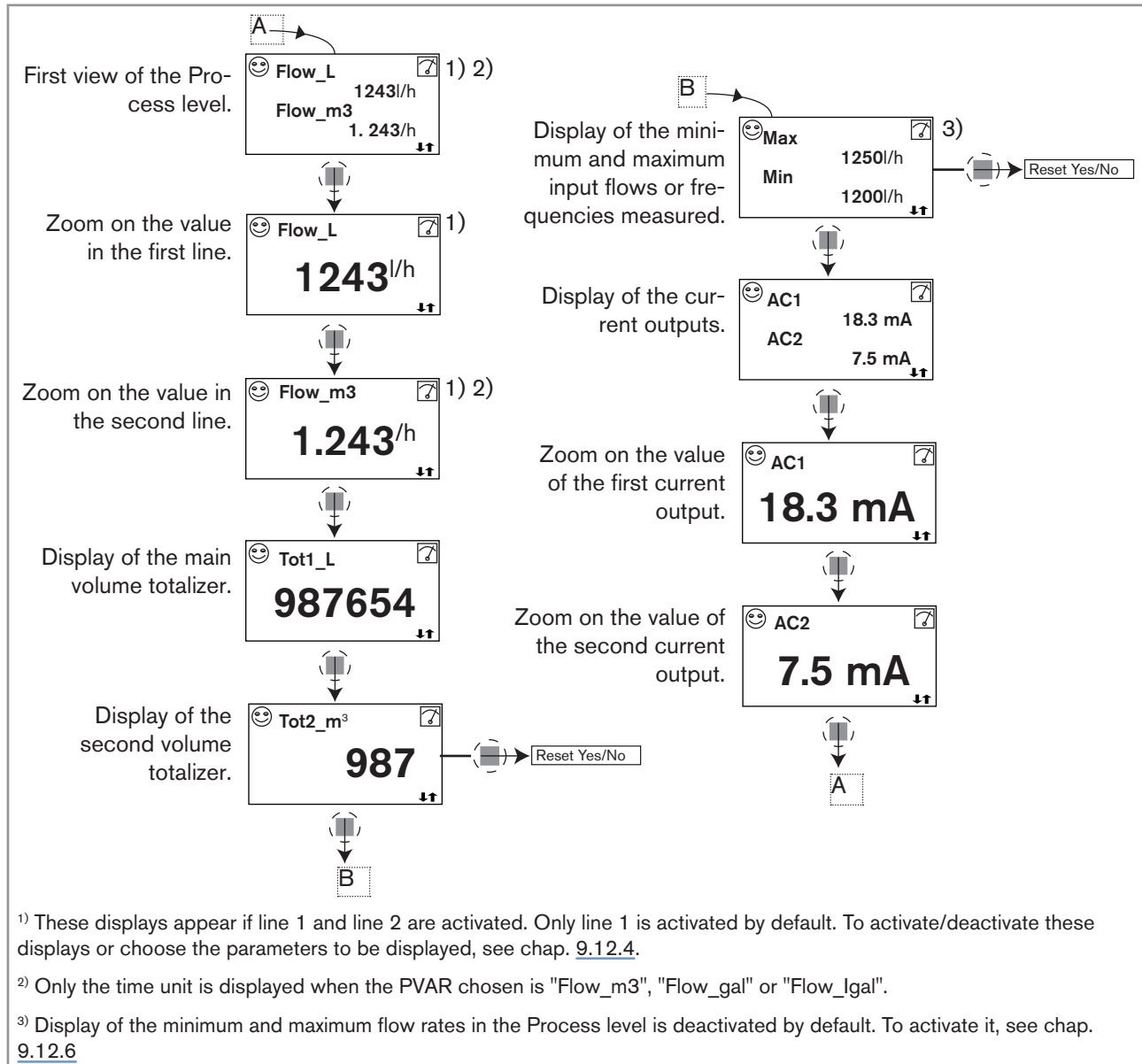

Figure 38 : Position of the icons and description of the LEDs

| Icon  | Possible cause and alternatives   |
|---|---|
|  | Sensor input frequency within the defined ranges<br>The alternatives, in this position, if monitoring of the sensor input frequency is activated, are: <ul style="list-style-type: none"> <li>, associated with  : see chap. 9.14.2 and chap. 10.3</li> <li>, associated with  : see chap. 9.14.2 and chap. 10.3</li> </ul> |
|  | The device is measuring.<br>The alternative icons in this position are: <ul style="list-style-type: none"> <li> flashing: HOLD mode activated (see chap. 9.13.1)</li> <li> : running check that the outputs are working and behaving correctly (see chap. 9.15.2 and 9.15.3)</li> </ul>   |
|  | "warning" message; See chap. 9.14.2 and chap. 10.3  |
|  | "error" message; See chap. 9.14.2 and chap. 10.3  |

## 9.9. Process level



## 9.10. Accessing the Configuration level

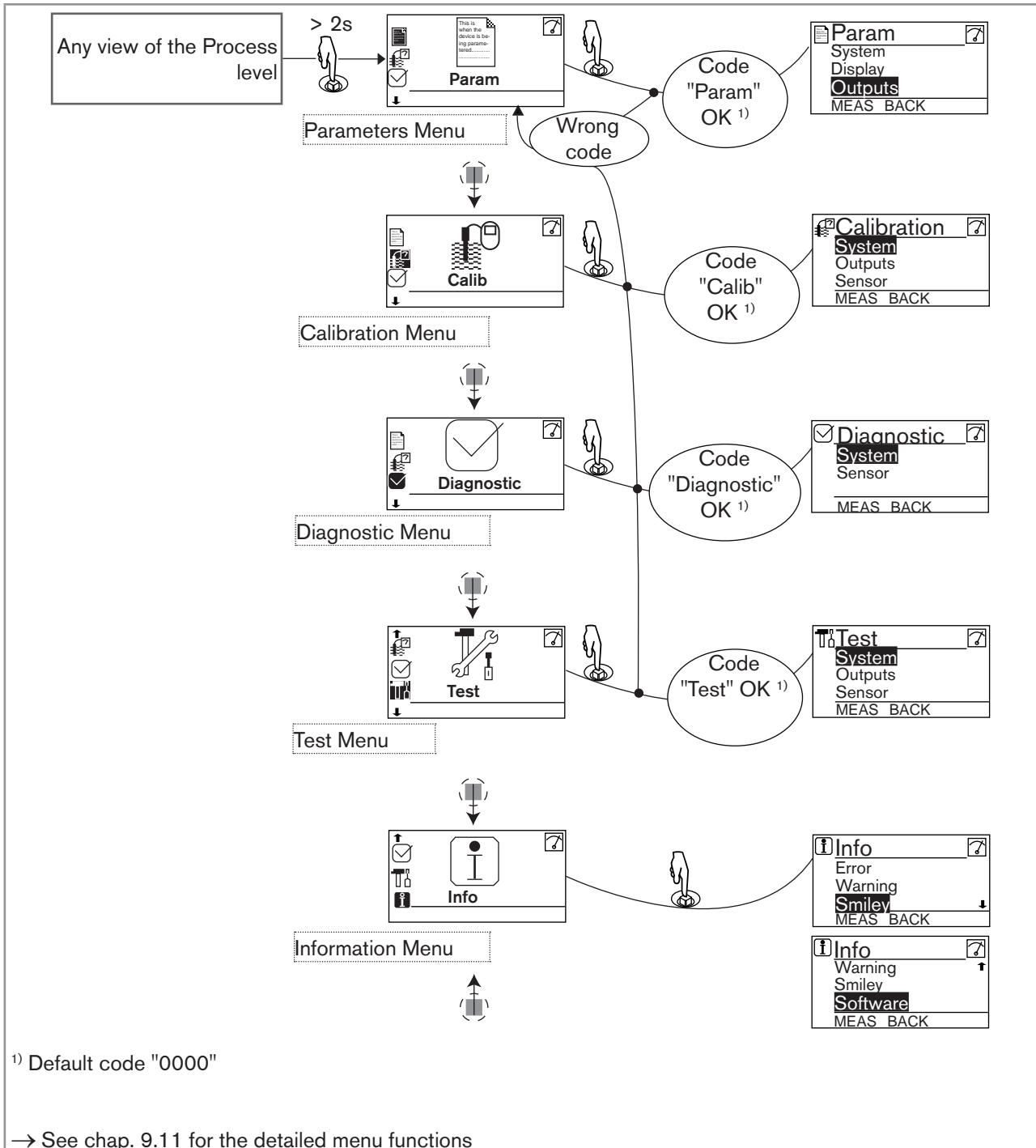

## 9.11. Structure of the Configuration menus

See chap. 9.10 to access the Configuration level.

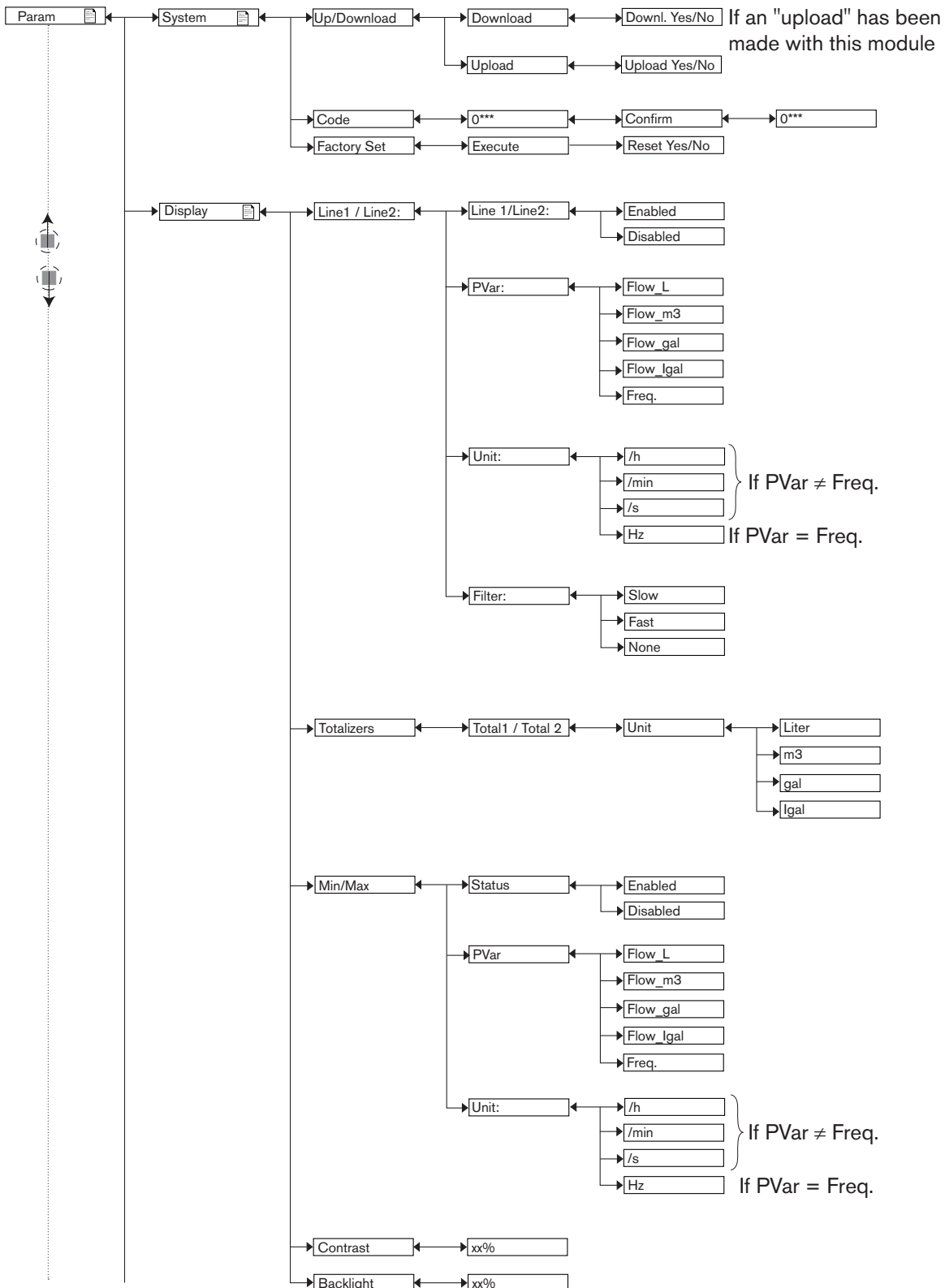

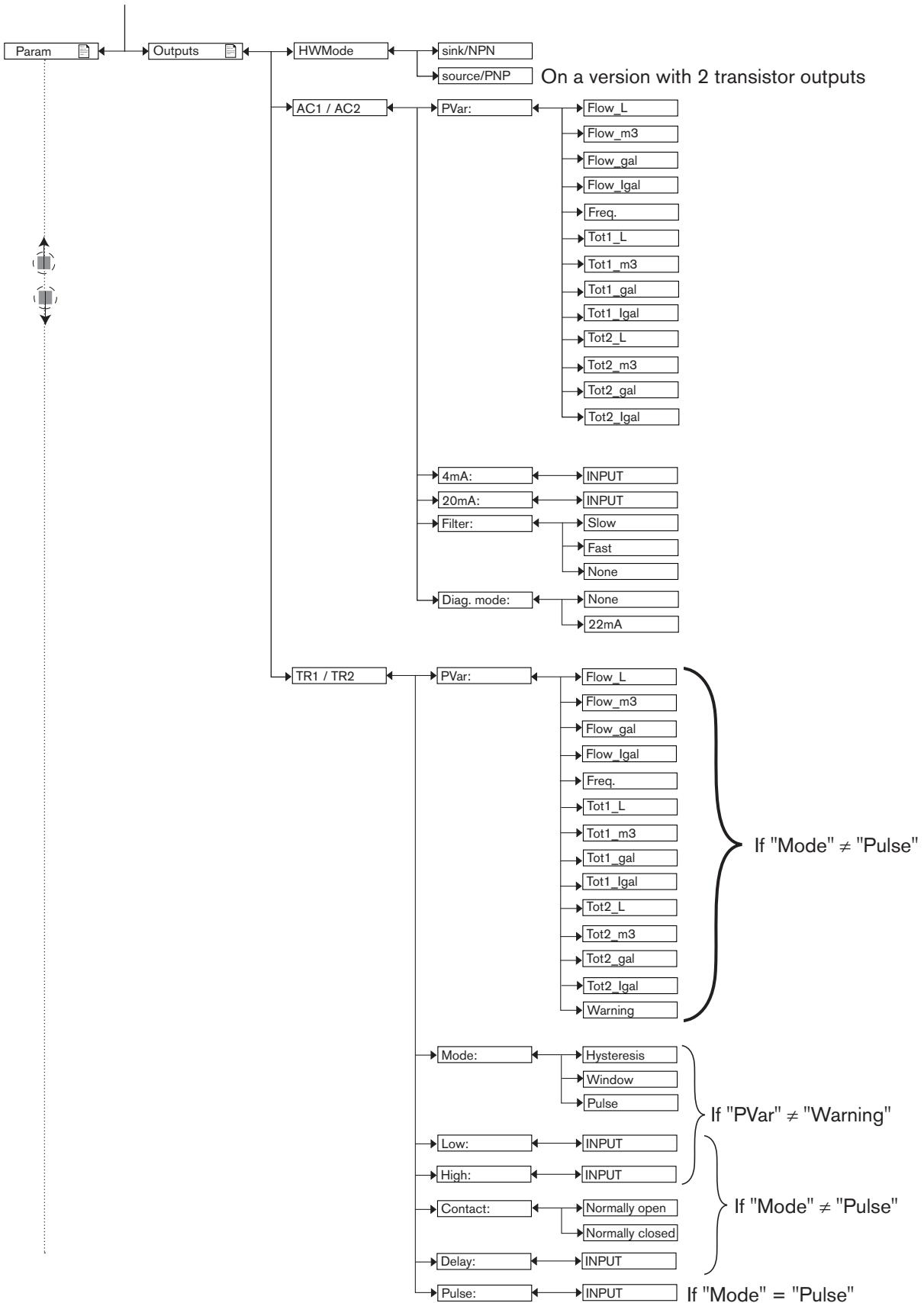

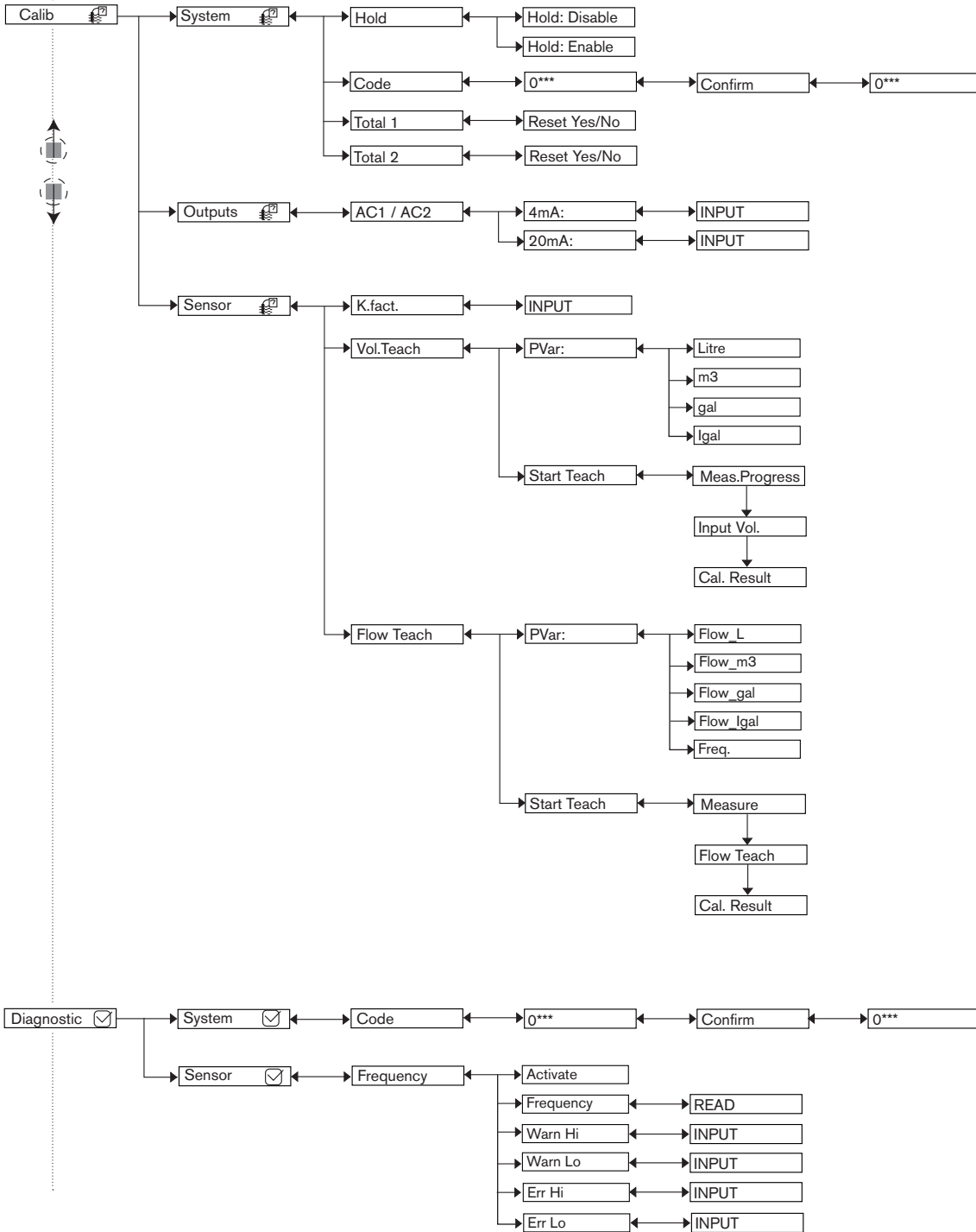

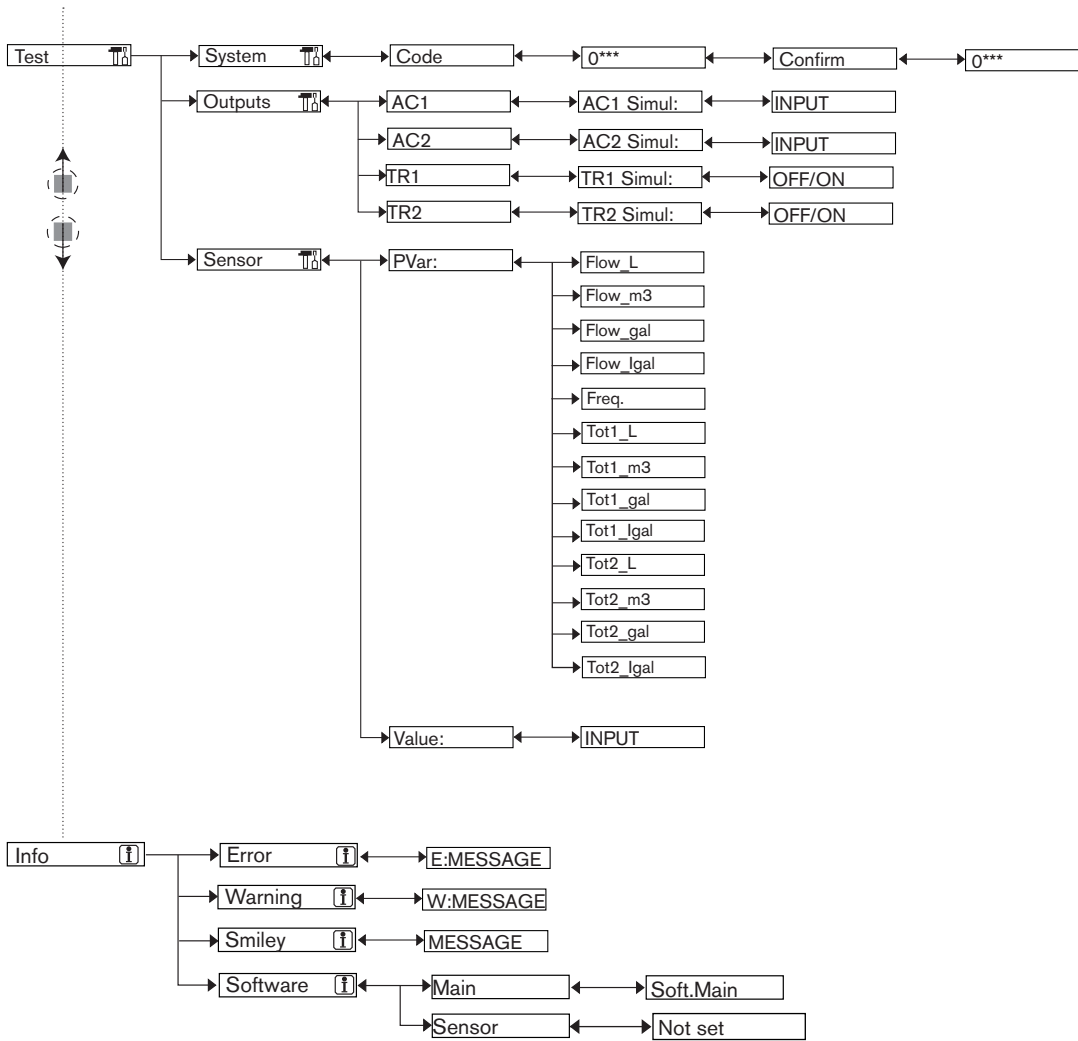

## 9.12. Parameters Menu

### 9.12.1. Transferring data from one device to another

See chap. [9.10](#) to access the Param menu.



This function is only possible with a display module with software version V2.

- The software version of the display module is displayed when the display module is turned on.





The data transfer is impossible from a device having an acquisition / conversion module for the process values measured with a V2 software version to a device having an acquisition / conversion module for the process values measured with a V1 software version.

- On each device, check the software version of the acquisition / conversion module for the process values measured, in the menu "Info -> Software -> Versions -> Main".



When transferring data from a device having an acquisition / conversion module for the process values measured with a V1 software version to a device having an acquisition / conversion module for the process values measured with a V2 software version, the following data are not transferred:

- the access codes to the menus,
- the wire mode of the outputs (fonction "HWMMode").



- Function "DOWNLOAD" is only present if an "UPLOAD" has been successfully carried out.
- Never interrupt a data transfer else the device could be damaged.

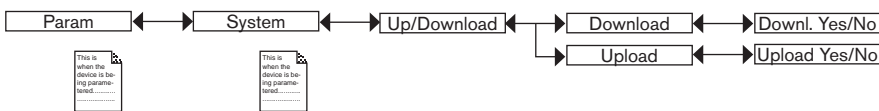

The following data can be transferred from a device to another device of the same type:

- user set data of the PARAM menu (except the date, the time, the contrast and brightness levels for the display),
- K factor of the fitting,
- user set data of the DIAGNOSTIC menu,
- the access codes to the menus.

**DOWNLOAD:** transfer the data previously uploaded in the display module by means of the "UPLOAD" function.

The parameters transferred are used by the device as soon as the message "Download OK" is displayed.

**UPLOAD:** upload data from the device to the display module.

### 9.12.2. Modifying the PARAM menu access code

See chap. 9.10 to access the Param menu. The default access code is "0000".

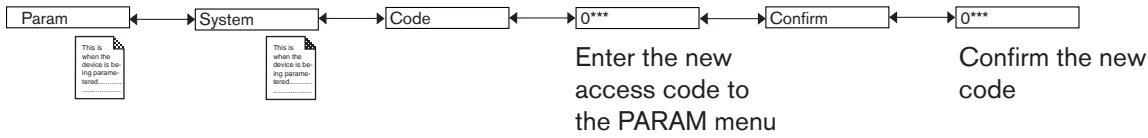

### 9.12.3. Restoring the default parameters of the Process level and the outputs

See chap. 9.10 to access the Param menu.

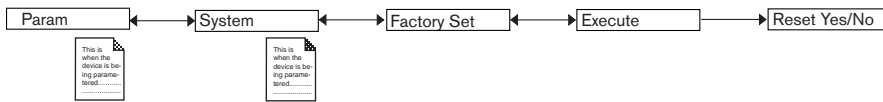

**EXECUTE** : restore (choose "Yes") the default parameters of the Process level and of the outputs, or keep the current parameters ( choose "No").

### 9.12.4. Setting the data displayed on lines 1 and 2 of the display module

See chap. 9.10 to access the Param menu.

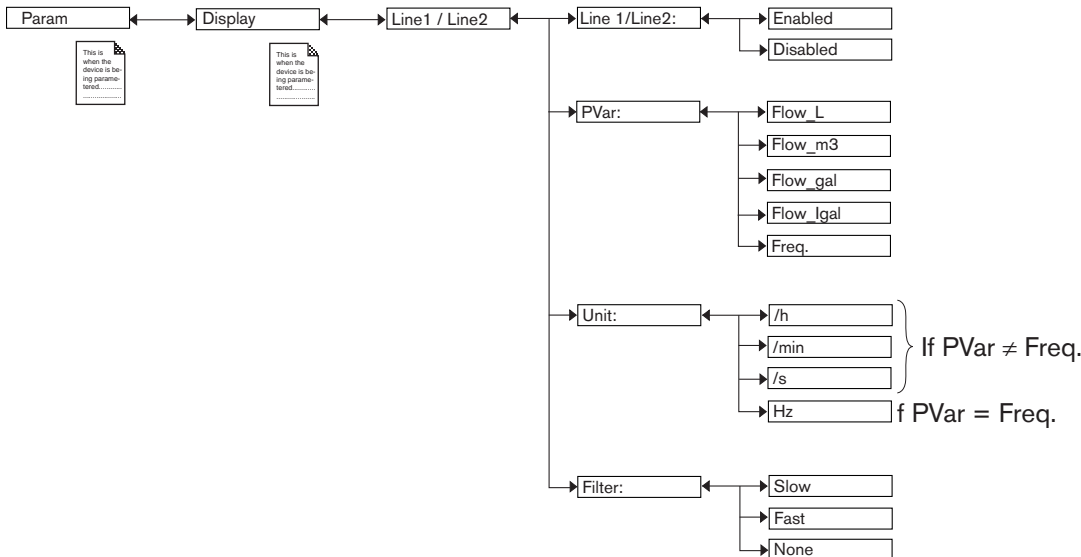

#### Activate or deactivate line 1 or line 2 respectively in Process level.

**LINE1** or **LINE2** : Activate (choice "Enabled") or deactivate (choice "Disabled") the display of line 1 or line 2 respectively.

#### Set the parameters of the data displayed in Process level on line 1 or line 2 respectively when the corresponding line is activated:

**PVAR**: Choose the flow rate volume unit or the input frequency to be displayed on line 1 or line 2 of the display respectively.

**UNIT:** Choose the preferred time unit in which the flow rate is displayed.



Take care to choose the time unit according to the flow rate in the pipes as the display indicates a maximum flow rate of 9999 volume units/time unit.

- If the flow rate measured is  $0 \leq \text{volume unit/h} \leq 9999$ , choose the time unit "/h" so that the display indicates a flow rate in volume units/h.
- If the flow rate measured is  $1 \leq \text{volume unit/min} \leq 9999$ , choose the time unit "/min" so that the display indicates a flow rate in volume units/min.
- If the flow rate measured is  $1 \leq \text{volume unit/s} \leq 9999$ , choose the time unit "/s" so that the display indicates a flow rate in volume units/s.
- If the flow rate measured is  $0 \leq \text{volume unit/min}$  or  $\text{volume unit/s} < 1$ , the display indicates a flow rate in volume units/h, regardless of the time unit chosen.
- If the flow rate measured is  $\geq 10000$  volume unit/h, the display indicates a flow rate  $166,66 \geq \text{volume units/min} \leq 9999$ , regardless of the time unit chosen.
- If the flow rate measured is  $\geq 10000$  volume unit/min, the display indicates a flow rate  $166,66 \geq \text{volume units/s} \leq 9999$ , regardless of the time unit chosen.
- If the flow rate measured is  $1 \leq \text{volume unit/min} < 60$ , the display indicates a flow rate in volume units/min, even if the time unit chosen is "/s".

| Selected time unit      | Measured flow rate   | Displayed flow rate   |
|-------------------------|--|---|
| /h<br>(default setting) | $\geq 0$ volume units/h and $\leq 9999$ volume units/h     | 0 to 9999 volume units/h  |
|                         | $\geq 10000$ volume units/h                                | 10000/60 volume units/min to 9999 volume units/min, i.e. 166,66 volume units/min to 9999 volume units/min |
|                         | $\geq 10000$ volume units/min                              | 10000/60 volume units/s to 9999 volume units/s, i.e. 166,66 volume units/s to 9999 volume units/s         |
| /min                    | $< 1$ volume units/min                                     | 0 to 59,99 volume units/h   |
|                         | $\geq 1$ volume units/min and $\leq 9999$ volume units/min | 1 to 9999 volume units/min  |
|                         | $\geq 10000$ volume units/min                              | 10000/60 volume units/s to 9999 volume units/s, i.e. 166,66 volume units/s to 9999 volume units/s         |
| /s                      | $< 1$ volume units/min                                     | 0 to 59,99 volume units/h   |
|                         | $\geq 1$ volume units/min and $< 60$ volume units/min      | 1 to 59,99 volume units/min   |
|                         | $\geq 1$ volume units/s and $\leq 9999$ volume units/s     | 1 to 9999 volume units/s  |

**Attenuate the measurement variations on the display**

**FILTER:** choose the filter level for the flow rate or frequency measured values displayed on the line selected. Three damping levels are proposed: "slow" (slow filter), "fast" (fast filter) or "none" (no filter).

MAN 1000182212 EN Version: A Status: RL (released | freigegeben) printed: 19.01.2015

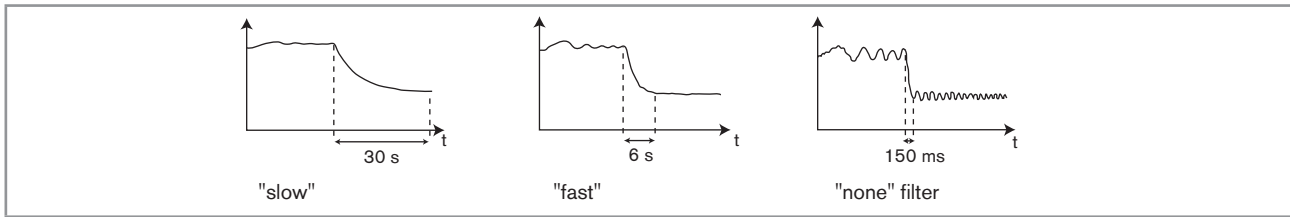
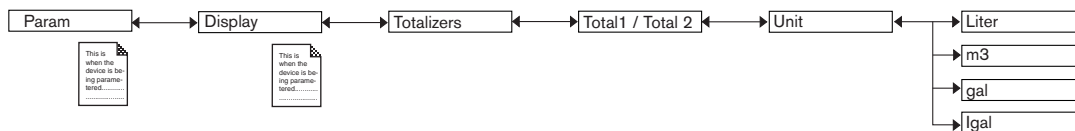

Figure 39 : Filter curves

### 9.12.5. Choosing the units for the totalizers displayed in Process level

See chap. 9.10 to access the Param menu.

**!** The totalizers are saved if a power cut occurs.



**UNIT:** Choose the volume unit in which the value of totalizer 1 and totalizer 2 respectively is displayed.

### 9.12.6. Displaying the lowest and highest values measured

See chap. 9.10 to access the Param menu.

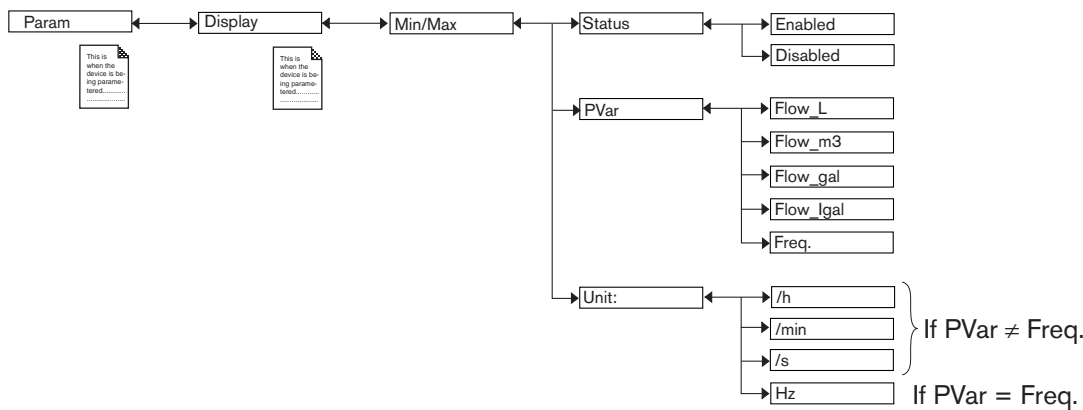

**STATUS:** Choose to display (choice “Enabled”) or not display (choice “Disabled”) the minimum and maximum values measured since the last reset.

**PVAR:** Choose a physical parameter (volume unit of the flow rate or input frequency), the minimum and maximum measured values of which are displayed in Process level.



**UNIT:** Choose the preferred time unit in which the min. and max. measured flow rate values are displayed.

**!** Take care to choose the time unit according to the flow rate in the pipes as the display indicates a maximum flow rate of 9999 volume units/time units. See chap. 9.12.4.

### 9.12.7. Setting the parameters for the reading comfort level of the data displayed

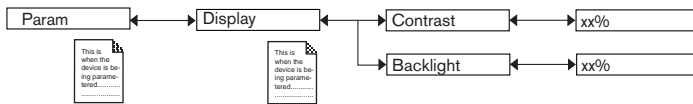
See chap. 9.10 to access the Param menu.



Set each percentage using  and .

**CONTRAST:** Choose the display contrast level (as a %).

**BACKLIGHT:** Choose the light intensity of the display (as a %) on a version with 2 fixed connectors only.

These settings only affect the display module. They are not factored in during a device data UPLOAD (see chap. 9.12.1).

### 9.12.8. Defining the connection mode of the outputs

See chap. 9.10 to access the Param menu.

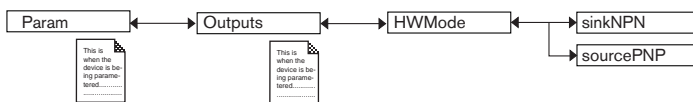

On a version of the device with an NPN transistor output and a current output, only the choice "sink/NPN" is possible.



The setting has no effect on a version with one fixed connector, 2 transistor outputs and a single current output, if the sole current output is wired. See [Figure 21](#).

The wiring mode is the same for all outputs.

If you choose "sink NPN", the current outputs must be wired in sinking mode and the transistor outputs in NPN mode.

If you choose "source PNP", the current outputs must be wired in sourcing mode and the transistor outputs in PNP mode.



See the wiring for the outputs in chap. 8.3.

### 9.12.9. Setting the parameters of the current outputs

See chap. 9.10 to access the Param menu. The 2nd current output "AC2" is only available on a version with 2 current outputs.

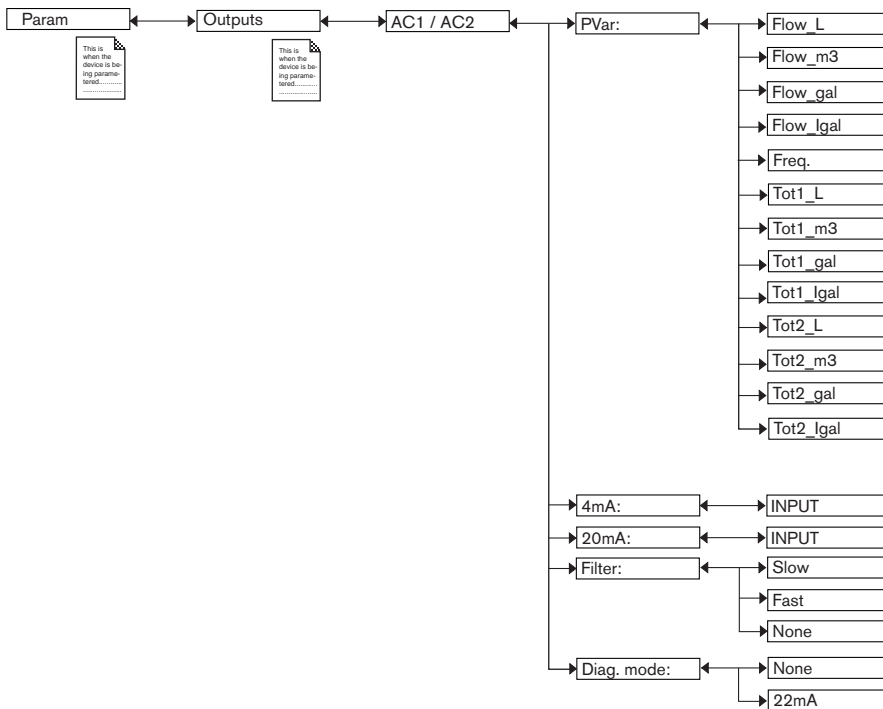

Functions "4mA" and "20mA" are used to define the measurement range for the flow rate, the input frequency or the totalizer associated with the current on the 4-20 mA output.

$P_1$  and  $P_2$  are the values associated with a current of 4 mA or 20 mA respectively:  $P_1$  may be greater than  $P_2$  : if this is the case, the signal is inverted and range  $P_1$ - $P_2$  corresponds to the range for the 20-4 mA current.

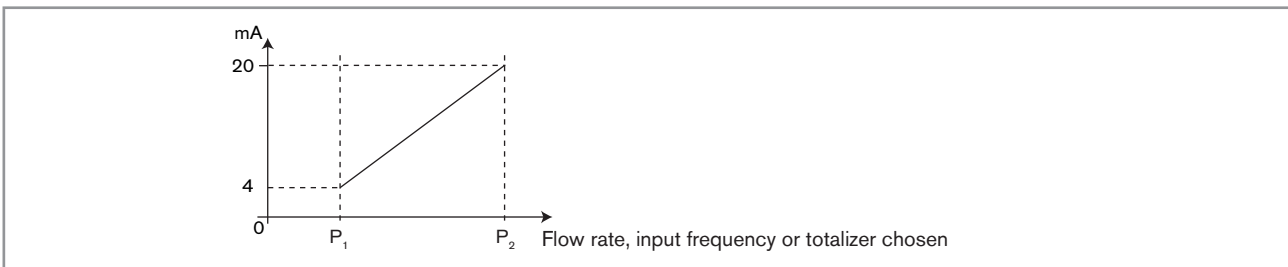

Figure 40 : 4-20 mA current according to the chosen physical parameter or totalizer

**PVAR:** Choose a physical parameter (flow rate volume unit or input frequency) or a totalizer combined with current output 1 or current output 2 respectively.

**4mA:** Choose the value of the physical parameter or the totalizer (previously selected) and the flow time unit, combined with a current of 4 mA for each current output. See "Current output parameters", next page.

**20mA:** Choose the value of the physical parameter or the totalizer (previously selected) and the flow time unit, combined with a current of 20 mA for each current output. See "Current output parameters", next page.

**FILTER:** choose the level of damping for the fluctuations of the current value for each current output. Three damping levels are proposed: "slow", "fast" or "none".

The damping for the current outputs is similar to the damping of the display. See [Figure 39](#).

**DIAG MODE:** choose to emit a current of 22 mA on the current output selected when an "error" event related to diagnostics (see chap. [9.14.2](#) and ) is generated by the device or allow the current output to operate normally (choose "none").



See also "If you encounter problems" in chap. 10.3

### 9.12.10. Setting the parameters of the transistor outputs

See chap. 9.10 to access the Param menu. The 2nd transistor output "TR2" is only available on a version with 2 transistor outputs.

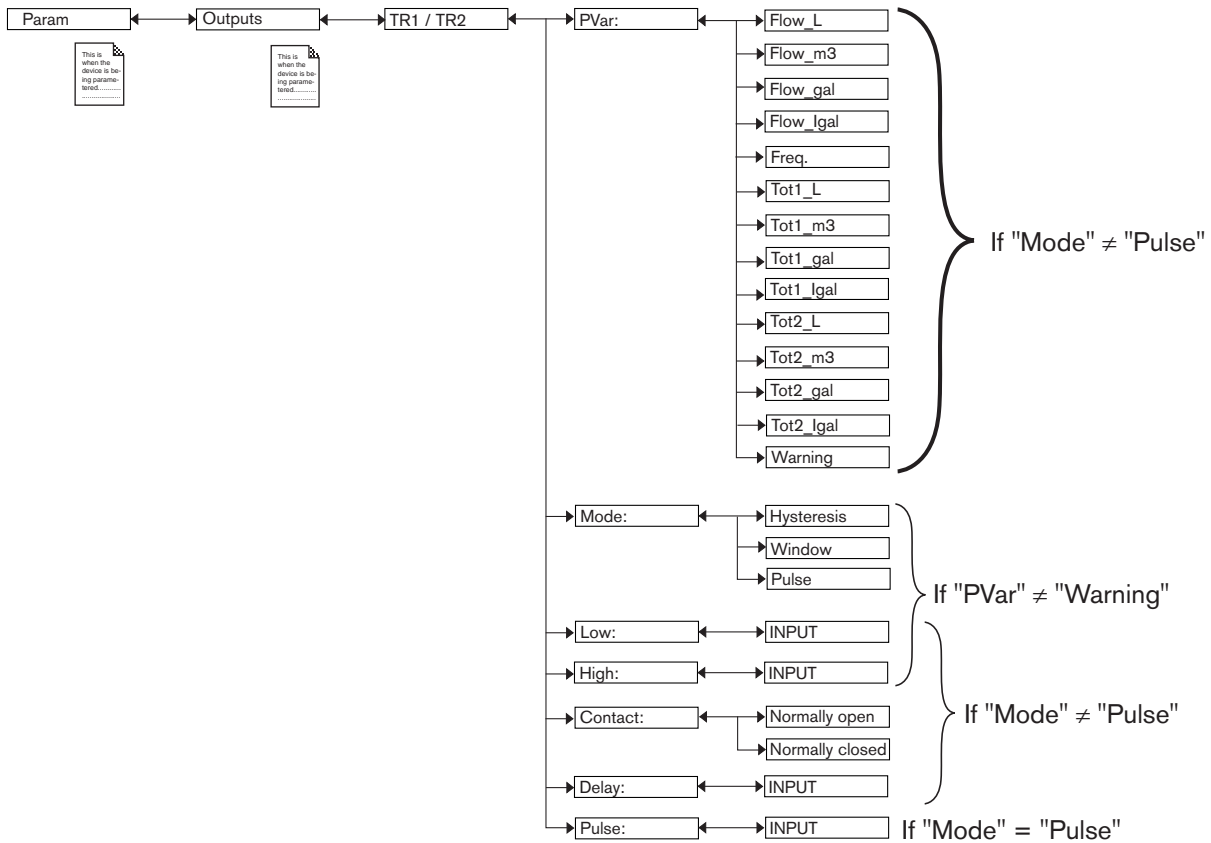

**PVAR:** Choose a physical parameter (flow rate volume unit or input frequency) or a totalizer associated with transistor output 1 or transistor output 2 respectively or associate the "warning" event (see chap. 9.14.2) with transistor output 1 or transistor output 2 respectively. If the selected transistor output is linked to the "warning" event, the transistor switches as soon as such an event is generated by the device.

**MODE:** Choose either the hysteresis or window operating mode, for transistor output 1 or transistor output 2, or operating on pulse mode (choice "Pulse") for transistor output 1 or transistor output 2.

**LOW:** enter the low switching threshold value for transistor output 1 or transistor output 2, as well as the flow rate time unit. See details on next page.

**HIGH:** enter the high switching threshold value for transistor output 1 or transistor output 2, as well as the flow rate time unit. See details on next page.

**CONTACT:** choose the type of off-position (normally open, NO, or normally closed, NC) for transistor output 1 or transistor output 2. See details on next page.

**DELAY:** choose the value of the time delay prior to switching (from 0 to 60 s) for each transistor output. The time delay before switching is applicable to both switching thresholds.

MAN 1000182212 EN Version: A Status: RL (released | freigegeben) printed: 19.01.2015

Switching only occurs if one of the thresholds, high or low (functions "High" or "Low"), is exceeded for a duration longer than this time delay.

**PULSE:** When the choice "Pulse" is selected in MODE function above, enter here the volume of fluid for which a pulse must be transmitted on transistor output 1 or transistor output 2 respectively.

### Hysteresis operating

The output status changes when a threshold is reached:

- by increasing flow rate, the output status changes when the high threshold ("high") is reached.
- by decreasing flow rate, the output status changes when the low threshold ("low") is reached.

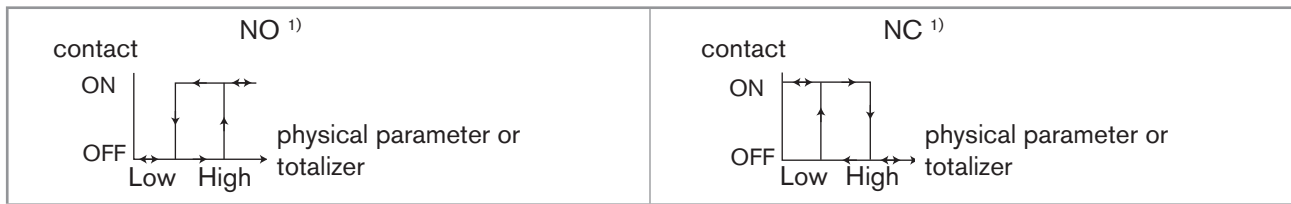

Figure 41 : Hysteresis operating

NO = Normally open ; NC = Normally closed

### Window operating (choice "Window"):

The change of status occurs whenever one of the thresholds is detected.



Figure 42 : Window operating

<sup>1)</sup> NO = Normally open ; NC = Normally closed

### Pulse operating (choice "Pulse")

This function is used to generate a pulse on the transistor output each time a predetermined volume of fluid passes.

Enter the desired fluid volume and, if necessary, modify the volume units/pulse in the "PULSE" function in the "Output. TR1" or "Output.TR2" menu



- A "Warning" event is emitted and the message "W:TRnPu too big" is displayed when the volume entered multiplied by the K factor of the device > 1000000.
- A "Warning" event is emitted and the message "W:TRnPu 1:1:set" is displayed when the volume entered multiplied by the K factor of the device < 1. In this case, the pulse frequency is forced to the value of the input frequency.



## 9.13. Calibration menu

### 9.13.1. Activating/deactivating the Hold function

See chap. 9.10 to access the Calib menu.

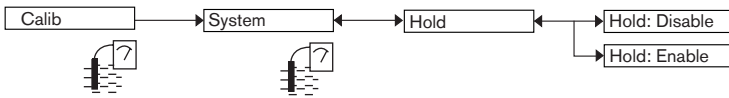

**!** The Hold mode is automatically deactivated when the device restarts after a power interruption, if the Hold mode was activated at the moment of the power cut-off.

The Hold mode is used to carry out maintenance work without interrupting the process.

To activate the HOLD mode:

- access the "HOLD" function;
- choose "enabled";
- confirm by "OK".

In practice, when the device is in Hold mode:

- the icon is displayed in place of the icon;
- the current emitted on each 4-20 mA output is fixed at the value of the last measurement of the physical parameter associated with each output;
- each transistor output is fixed at the status acquired at the moment the Hold function is activated;

**!** The Hold mode has no effect on the transistor outputs when they are operating in "Pulse" mode. See chap. 9.12.10.

- the device is in Hold mode until the HOLD function is deactivated.

To deactivate the HOLD mode:

- access the "HOLD" function;
- choose "disabled";
- confirm by "OK".

### 9.13.2. Modifying the Calibration menu access code

See chap. 9.10 to access the Calib menu. The default access code is "0000".

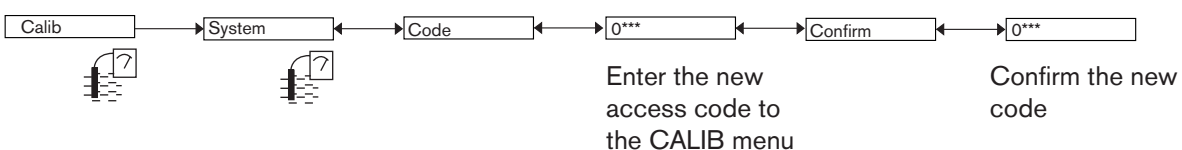

### 9.13.3. Resetting totalizer 1 or totalizer 2 respectively

See chap. 9.10 to access the Calib menu.

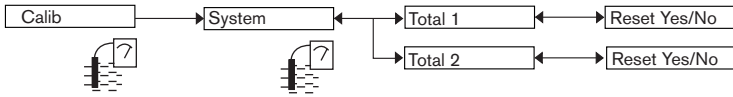

TOTAL 1 or TOTAL 2 respectively: Reset (choice "Yes") or do not reset (choice "No") totalizer 1 or totalizer 2 respectively.



Totalizer 2 can be reset from Process level. See chap. 9.9.

### 9.13.4. Adjusting the current outputs



#### WARNING

**Risk of injury due to wrong adjustment.**

- Make sure the Hold mode is disabled (see chap. 9.13.1).

See chap. 9.10 to access the Calib menu.

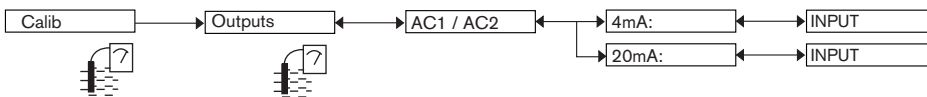

The entered values are not memorised in this menu. Only the values emitted on the current outputs are adjusted after pressing "OK" when the message "Recalibrate AC outputs?" is shown.

4mA: adjust the offset of current output 1 or current output 2.

When the "4mA" function is selected, the device generates a current of 4 mA: measure the current emitted by the 4-20 mA output using a multimeter and enter the value given by the multimeter in the function "AC1.4mA" or "AC2.4mA".

20mA: Adjust the span of current output 1 or current output 2.

When the "20mA" function is selected, the device generates a current of 20 mA: measure the current emitted by the 4-20 mA output using a multimeter and enter the value given by the multimeter in the function "AC1.20mA" or "AC2.20mA".

### 9.13.5. Entering the K factor or determining it with Teach-in

See chap. 9.10 to access the Calib menu.

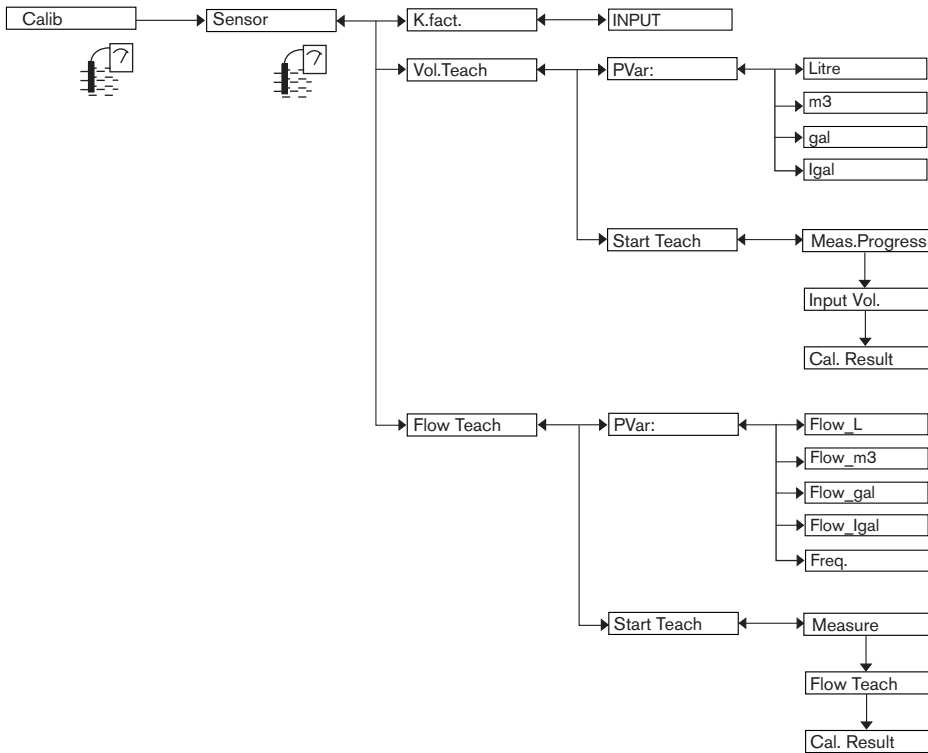

*K.FACT.:* Enter the K factor of the fitting used.

*VOL.TEACH:* Determine the fitting K factor using a teach-in procedure depending on a volume. See details of the procedure below.

*FLOW TEACH:* Determine the fitting K factor using a teach-in procedure depending on the flow rate. See details of the procedure on page 59

#### Detailed procedure of a Teach-in by volume (“Vol.Teach” function in the “Sensor” menu)

→ Prepare a tank capable of containing 100 litres, for example.

→ Choose the volume unit in which the teach-in is run:

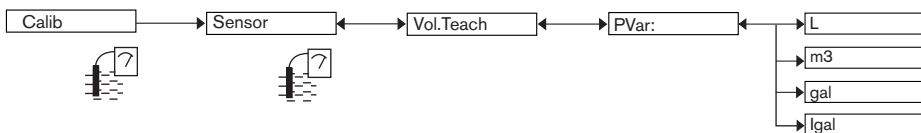

→ Run the teach-in:

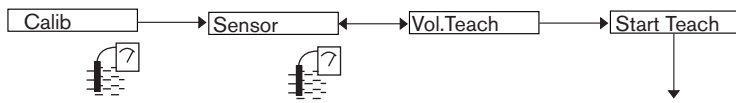

→ Open the valve to fill the tank.

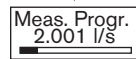

The device displays the instantaneous flow of the fluid.

→ When the tank is filled, close the valve.

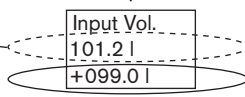

The device displays the volume calculated with the current K factor. If the display shows “++++”, the volume calculated > 9999 volume units: continue the procedure as normal.

→ Enter the actual volume of fluid in the tank.



The device displays the K factor calculated by teach-in.

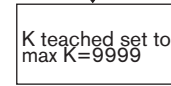
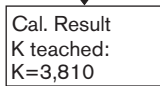

If the calculated K factor is  $\geq 9999$ , it is forced to 9999.

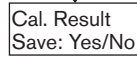

→ Save the new K factor calculated or not.

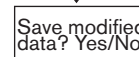

→ Confirm the K factor =9999 with “YES” or keep the current K factor with “NO”.

**Detailed procedure of a Teach-in by flow rate (“Flow.Teach” function in the “Sensor” menu)**

→ Choose the volume unit in which the teach-in is run:

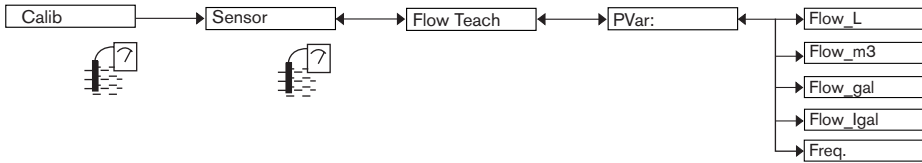

→ Run the teach-in:

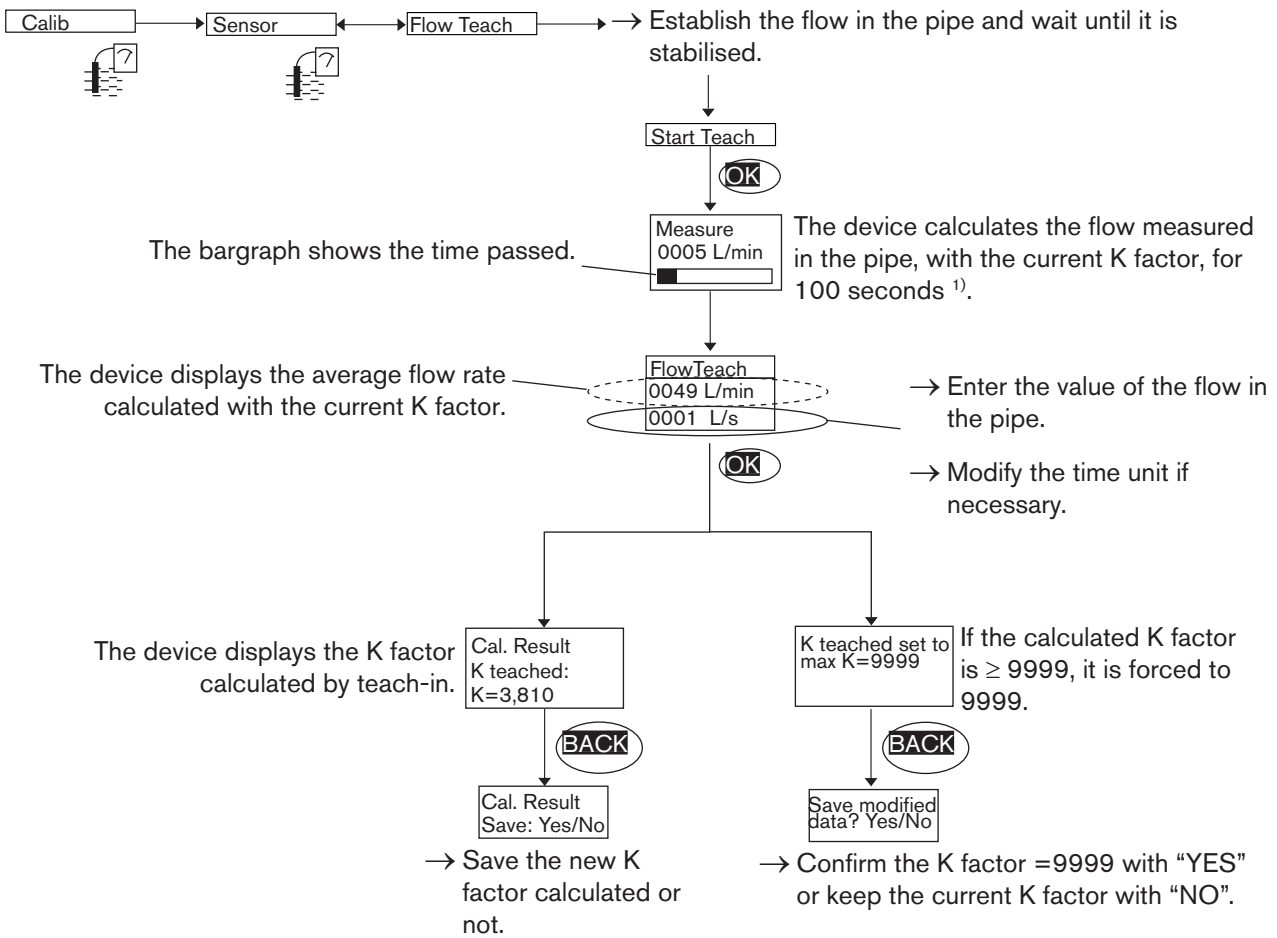

<sup>1)</sup> Measurement can be suspended at any time by selecting “OK”.

## 9.14. Diagnostic menu

### 9.14.1. Modifying the Diagnostic menu access code

See chap. 9.10 to access the Diagnostic menu. The default access code is "0000".

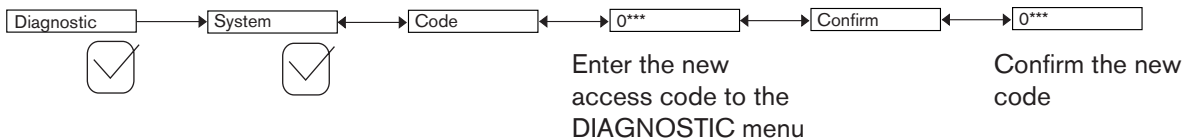

### 9.14.2. Monitoring the sensor input frequency

See chap. 9.10 to access the Diagnostic menu.

A malfunction in your process or the sensor may be revealed by an out-of-range input frequency.

The function allows for monitoring the sensor input frequency and configure the behaviour of the device if the parametered ranges are exceeded.

The sensor input frequency  $f$  is used to determine the flow  $Q$  in the pipes using the formula  $f = KQ$  (the  $K$  factor being expressed in pulses/s and the flow rate  $Q$  in l/s).

To be warned when the input frequency is out of range:

- activate monitoring of the sensor input frequency in the function "activate", then
- enter an input frequency range outside of which the device generates a "warning" event and displays the icons ☺ and ⚠.
- enter an input frequency range outside of which the device generates an "error" event and displays the icons ☹ and ERR.

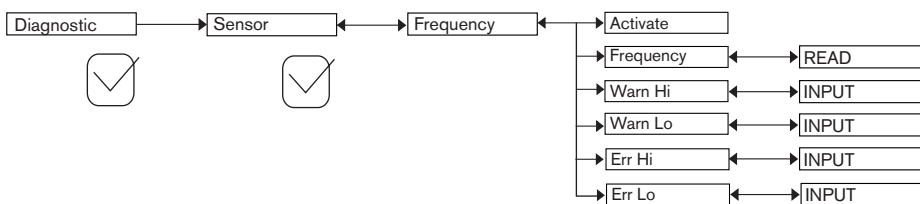

**ACTIVATE:** choose whether or not to activate monitoring of the sensor input frequency.

This monitoring is done by the generation of a "warning" event if the input frequency range defined in the "Warn hi/lo" functions below is exceeded and an "error" event if the input frequency range defined in the "Err hi/lo" functions below is exceeded.

**FREQUENCY:** read the sensor input frequency

**WARN HI:** enter the input frequency value above which a "warning" event is generated.

**WARN LO:** enter the input frequency value below which a "warning" event is generated.

**ERR HI:** enter the input frequency value above which an "error" event is generated.

**ERR LO:** enter the input frequency value below which an "error" event is generated.

When the device generates a "warning" or "error" event:

- go into the "Info" menu to read the cause of the event generation.
- and/or go into the "Sensor" function of the Diagnostic menu to read the measured input frequency.
- if necessary, clean the paddle or the oval gears.
- if necessary, check the process.

- The "warning" event may also be associated with one or other or both transistor outputs. See chap. 9.12.9, function "Output.TR1" or "Output.TR2".
- The "error" event may also be associated with one or other or both current outputs. See chap. 9.12.10, function "Output.AC1" or "Output.AC2".
- See also "If you encounter problems" at chap. 10.3

## 9.15. Test menu

### 9.15.1. Modifying the Test menu access code

See chap. 9.10 to access the Test menu. The default access code is "0000".

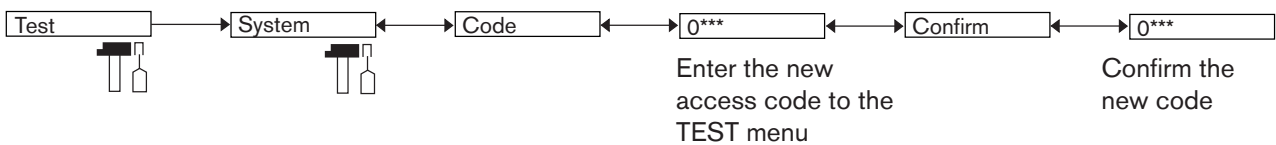

### 9.15.2. Checking the outputs functions

See chap. 9.10 to access the Test menu.

The icon is displayed in place of the icon as soon as the check for the correct working of an output has started. During the check the related output does not react according to the measured physical value.

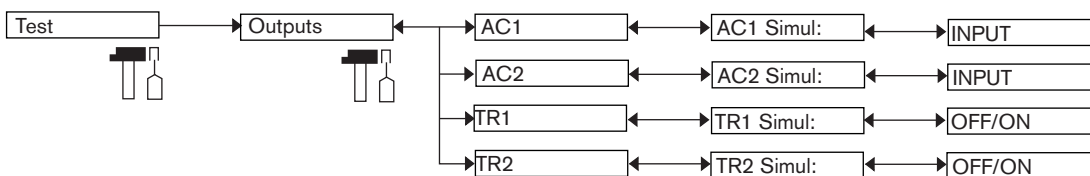

**AC1:** check that current output 1 is working correctly by entering a current value in mA and then selecting "OK".

**AC2:** check that current output 2 is working correctly by entering a current value in mA and then selecting "OK".

**TR1:** check that transistor output 1 is working correctly by selecting the status of the transistor ("ON" or "OFF") then "OK".

**TR2:** check that transistor output 2 is working correctly by selecting the status of the transistor ("ON" or "OFF") then "OK".

### 9.15.3. Checking the outputs behaviour

See chap. 9.10 to access the Test menu.

The feature allows for simulating the measurement of the physical parameter or the value of the totalizer to check if the outputs are correctly configured.

**!** The **T** icon is displayed in place of the **?** icon as soon as the check for the correct working of an output has started. During the check the related output does not react according to the measured physical value.

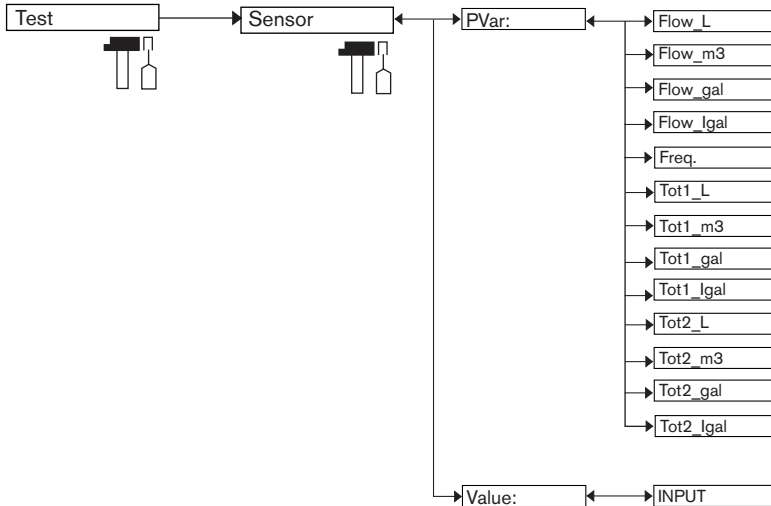

*PVAR*: choose the physical parameter or the totalizer to be tested.

*VALUE*: enter a physical parameter value by modifying the flow time unit or a totalizer value, depending on the choice made in the “PVAR” function above, to check output behaviour.

### 9.16. Information Menu

See chap. 9.10 to access the Info menu.

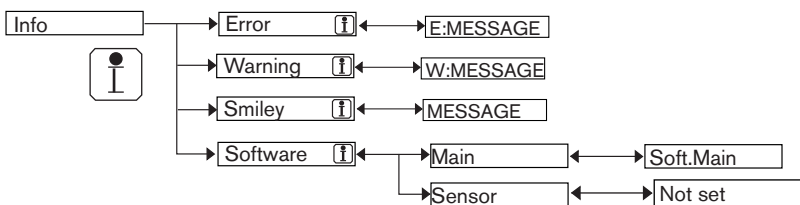

This menu makes it possible to read:

- a short description of the cause that generated an event related to the following icons, when they are displayed by the device:
  - ERROR:
  - WARNING:
  - SMILEY: or

**i** See also "If you encounter problems" at chap. 10.3

- the software version (function “SOFTWARE”) of the acquisition/conversion board for the physical parameters measured.



# 10. MAINTENANCE AND TROUBLESHOOTING

## 10.1. Safety instructions

### DANGER

**Risk of injury due to high pressure in the installation.**

- Stop the circulation of fluid, cut off the pressure and drain the pipe before loosening the process connections.

**Risk of injury due to electrical voltage.**

- Shut down and isolate the electrical power source before carrying out work on the system.
- Observe all applicable accident protection and safety regulations for electrical equipment.

**Risk of injury due to the nature of the fluid.**

- Respect the prevailing regulations on accident prevention and safety relating to the use of aggressive fluids.

### WARNING

**Risk of injury due to non-conforming maintenance.**

- Maintenance must only be carried out by qualified and skilled staff with the appropriate tools.
- Ensure that the restart of the installation is controlled after any interventions.

## 10.2. Cleaning the device









The device can be cleaned with a cloth dampened with water or a detergent compatible with the materials the device is made of.

Please feel free to contact your Bürkert supplier for any additional information.

The fouling of the paddle-wheel may result in a drift of the flow rate measurement.  
→ Clean the paddle-wheel according to the type of fouling.

## 10.3. If you encounter problems

| Red LED | Current output      | Transistor output       | Icon | Message displayed in the Info menu | Possible cause   | Recommended action   |
|---------|---------------------|-------------------------|------|------------------------------------|--|--|
| ON      | 22 mA <sup>1)</sup> | depending on thresholds | +    | "Sensor not found"                 | The connection to the measurement module is interrupted. | → Switch the power supply off then on again.<br>→ If the error persists, return the device to Bürkert. |

| Red LED | Current output      | Transistor output       | Icon  | Message displayed in the Info menu         | Possible cause  | Recommended action  |
|---------|---------------------|-------------------------|---|--|---|---|
| ON      | 22 mA <sup>1)</sup> | depending on thresholds |  +      | "TR EE Fact Read"<br><br>"TR EE User Read" | Parameter reading error.  | → Switch the power supply off then on again.<br><br>→ If the error persists, set the device back to the default settings (chap. <a href="#">9.12.3</a> ).<br><br>→ If the error persists, return the device to Bürkert.   |
| ON      | 22 mA <sup>1)</sup> | depending on thresholds |  +      | "TR EE UserWrite"                          | Parameter saving error.   | → Switch the power supply off then on again.<br><br>→ Save the settings again.<br><br>→ If the error persists, set the device back to the default settings (chap. <a href="#">9.12.3</a> ).<br><br>→ If the error persists, return the device to Bürkert.             |
| ON      | 22 mA <sup>1)</sup> | depending on thresholds |  +  | "E:Frequency"                              | The input frequency is out of range.<br><br>This message is displayed if monitoring of the input frequency is activated, depending on the set thresholds ERR LO and ERR HI (see chap. <a href="#">9.14.2</a> ).   | → Go into the "Sensor" function in the Diagnostic menu to read the value of the input frequency.<br><br>→ check that the paddle is clean and that it rotates freely on its axis or<br><br>→ check that the oval gears rotate freely.<br><br>→ check the installation. |
| OFF     | 4-20 mA             | Switched <sup>2)</sup>  |  +  | "W:Frequency"                              | The input frequency is out of range.<br><br>This message is displayed if monitoring of the input frequency is activated, depending on the set thresholds WARN LO and WARN HI (see chap. <a href="#">9.14.2</a> ). | → Go into the "Sensor" function in the Diagnostic menu to read the value of the input frequency.<br><br>→ check that the paddle is clean and that it rotates freely on its axis or<br><br>→ check that the oval gears rotate freely.<br><br>→ check the installation. |
| OFF     | 4-20 mA             | Switched <sup>2)</sup>  |    | "W:TRnPu too big"                          | In "Pulse" mode, the volume entered for a pulse is incorrect (see chap. <a href="#">9.12.10</a> ).  | → Enter an appropriate volume.<br><br>→ check the K factor.   |

| Red LED | Current output | Transistor output      | Icon | Message displayed in the Info menu | Possible cause  | Recommended action                                      |
|---------|----------------|------------------------|------|------------------------------------|---|---|
| OFF     | 4-20 mA        | Switched <sup>2)</sup> | △    | "W:TRnPu 1:1 set"                  | In "Pulse" mode, the volume entered for a pulse is incorrect (see chap. 9.12.10). | → Enter an appropriate volume.<br>→ check the K factor. |

<sup>1)</sup> if the DIAG MODE function of the "Output.AC1" or "Output.AC2" menu is set to "22 mA" (see chap. 9.12.9); else, the current output delivers a standard current between 4 and 20 mA

<sup>2)</sup> If the "PVAR" function of the "Output.TR1" and/or "Output.TR2" menus is set to "warning" (see chap. 9.12.10); else, the transistor outputs are operating depending on the set thresholds.

## 11. SPARE PARTS AND ACCESSORIES



### ATTENTION

**Risk of injury and/or damage caused by the use of unsuitable parts.**

Incorrect accessories and unsuitable replacement parts may cause injuries and damage the device and the surrounding area.

- Use only original accessories and original replacement parts from Bürkert.

| Spare part (only for flowmeters type 8026)    | Order code |
|---|------------|
| Set with 1 green FKM seal + 1 black EPDM seal | 552111     |
| Snap ring                                     | 619205     |
| Nut   | 619204     |

| Accessory  | Order code |
|--|------------|
| Display module   | 559168     |
| Black blank cover with EPDM seal                                   | 560948     |
| Black blank cover with EPDM seal                                   | 561843     |
| Transparent cover with EPDM seal                                   | 560948     |
| 5-pin female M12 female connector, moulded on shielded cable (2 m) | 438680     |
| 5-pin male M12 connector, to be wired                              | 560946     |
| 5-pin male M12 connector, moulded on shielded cable (2 m)          | 559177     |

## 12. PACKAGING, TRANSPORT

### NOTE

#### Damage due to transport

Transport may damage an insufficiently protected device.

- Transport the device in shock-resistant packaging and away from humidity and dirt.
- Do not expose the device to temperatures that may exceed the admissible storage temperature range.
- Protect the electrical interfaces using protective plugs.

## 13. STORAGE

### NOTE

#### Poor storage can damage the device.

- Store the device in a dry place away from dust.
- Storing temperature for type 8026: -10 to +60°C.
- Storing temperature for type SE36: -10 to +60°C.
- Storing temperature for the fitting: refer to the related manual

## 14. DISPOSAL OF THE PRODUCT

→ Dispose of the device and its packaging in an environmentally-friendly way.

### NOTE

**Damage to the environment caused by products contaminated by fluids.**

- Keep to the existing provisions on the subject of waste disposal and environmental protection.



#### note

Comply with the national and/or local regulations which concern the area of waste disposal.





