

Digital flow ELEMENT transmitter for continuous flow measurement



Type 8026 can be combined with...



Type S020
INSERTION fitting



Type 2101 (8692)
Continuous
TopControl system



Type 6213
Solenoid valve



Type 2030
On/Off Diaphragm
valve

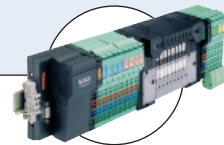

Type 8644
Valve islands



Type 8611
eCONTROL
universal controller

- PN10, DN15 to DN400 fluidic process connection
- Programmable outputs : one or two transistor output(s) and single or dual 4-20 mA analog output(s)
- Removable backlit display of flow and/or two totalized volumes
- Automatic-calibration: TEACH-IN, simulation of outputs signals provided without the need for real flow

The Bürkert transmitter Type 8026 is a compact device, specially designed for measuring the flow rate in solid-free liquids, in a variety of applications (water, waste water monitoring, chemical processing...).

The transmitter is equipped of a sensor with paddle-wheel, available in long or short version (depend on DN of used fitting). This sensor holder is plugged-in and pinned to an enclosure with cover, containing the electronic module. A removable display completes this transmitter.

The flow transmitter can operate without the display, but it will be required for programming the transmitter (i.e. set parameters, restore default parameters, programme information to be displayed, programme access codes, adjust 4-20 mA output(s) ...) and also for visualizing continuously the measured and processed data.

The device Type 8026 is available with:

- 2 programmable outputs : one transistor output (NPN) and one 4-20 mA current output (2-wire)
- 3 programmable outputs : two transistor outputs (NPN/PNP) and one 4-20 mA current output (2-wire)
- 4 programmable outputs: two transistor outputs (NPN/PNP) and two 4-20 mA current outputs (3-wire)

The device Type 8026 converts the measured signal, displays different values in different units (if display mounted) and computes the output signals, which are provided via one or two M12 fixed connectors. Thanks to 1 or 2 transistor outputs, the transmitter can be used to switch a solenoid valve, activate an alarm and, thanks to 1 or 2 current outputs, establish one or two control loops.

General data

Compatibility

Any pipe from DN 15 to 400 which are fitted out with Bürkert INSERTION Fitting S020 (see corresponding data sheet)

Materials

See exploded view, on next page
Housing
Stainless steel 1.4404, PPS
Cover
PC
Gaskets
EPDM
Screws
Stainless steel
Fixed connector mounting plate
Stainless steel 1.4404 (316L)
Fixed connector
Brass nickel plated
Display
PC
Navigation key
PBT
Nut
PC
Wetted part materials
PVDF
Sensor finger
FKM (standard)
Gasket
Ceramics (Al₂O₃)
Axis and bearings
PVDF
Paddle-wheel

Display (accessories)

Grey dot matrix 128 x 64 with backlighting

Electrical connections

2 or 3 outputs transmitter
1 x 5-pin M12 male fixed connector
4 outputs transmitter
1 x 5-pin M12 male and 1 x 5-pin M12 female fixed connectors

Connection cable

Shielded cable

8026 ELEMENT Transmitter



Complete device data (Pipe + transmitter)	
Pipe diameter	DN 15 to 400
Measuring range	0.3 up to 10 m/s
Medium temperature with fitting in PVC / PP PVDF, brass or stainless steel	0 up to 50°C (32 to 122°F) / 0 up to 80°C (32 to 176°F) -15 up to 100°C (5 to 212°F)
Medium pressure max.	PN10 (145 PSI) - see pressure / temperature chart
Viscosity / Particles rate	300 cSt max. / 1% max.
Measurement error Teach-In Standard K-factor	±1% of Reading (at Teach-In flow rate value) ¹⁾ ±2.5% of Reading ¹⁾
Linearity	±0.5% of F.S.* ¹⁾
Repeatability	±0.4% of Reading ¹⁾

¹⁾ Under reference conditions i.e. measuring fluid=water, ambient and water temperature=20°C (68°F), applying the minimum inlet and outlet pipe straights, matched inside pipe dimensions.

* F.S.=Full scale (10 m/s)

Electrical data	
Power supply 2 or 3 outputs transmitter (2-wire) 4 outputs transmitter (3-wire)	14-36 V DC, filtered and regulated 12-36 V DC, filtered and regulated
Characteristics of the power source (not provided) of UL recognized devices	Limited power source (according to § 9.3 of the UL61010-1 standard) or, Class 2 type power source (according to the 1310/1585 and 60950-1 standards)
Current consumption with sensor 2 or 3 outputs transmitter (2-wire) 4 outputs transmitter (3-wire)	≤ 1 A (with transistors load) ≤ 25 mA (at 14 V DC without transistors load, with current loop) ≤ 5 mA (at 12 V DC without transistors load, without current loop)
Power consumption	40 W max.
Reversed polarity of DC	Protected
Voltage peak	Protected
Short circuit	Protected for transistor outputs
Output Transistor 1 Transistor output (Transmitter 2-wire) 2 Transistor outputs (Transmitter 2 or 3-wire) Current 1 Current output (Transmitter 2-wire) 2 Current outputs (Transmitter 3-wire)	NPN, open collector, 1 - 36 V DC, max. 700 mA Configurable as sourcing or sinking (respectively both as PNP or NPN), open collector, max. 700 mA, 0.5 A max. per transistor if the 2 transistor outputs are wired NPN-output: 1 - 36 V DC PNP-output: Power supply 4-20 mA programmable as sourcing or sinking (in the same mode as transistor), max. loop impedance: 1100 Ω at 36 V DC ; 610 Ω at 24 V DC; 180 Ω at 14 V DC max. loop impedance: 1100 Ω at 36 V DC; 610 Ω at 24 V DC; 100 Ω at 12 V DC
4... 20 mA measurement error	±1%

Environment	
Ambient temperature	-10 up to +60°C (14 to 140°F) (operating and storage)
Relative humidity	≤ 85%, without condensation

Standards, directives and approvals	
Protection class	IP65, IP67, NEMA250 4X with M12 cable plug mounted and tightened and cover fully screwed down
Standard and directives 	EN 61000-6-2 (2005), EN 61000-6-3 (2001) Complying with article 3 of §3 from 97/23/CE. directive* EN 60068-2-6 / EN 60068-2-27
Approvals UL-Recognized for US and Canada 	UL61010-1 + CAN/CSA-C22 No.61010-1

bürkert

Pressure / temperature chart

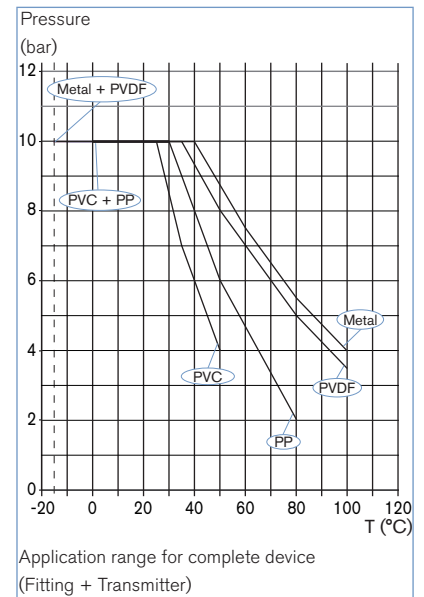

Materials view

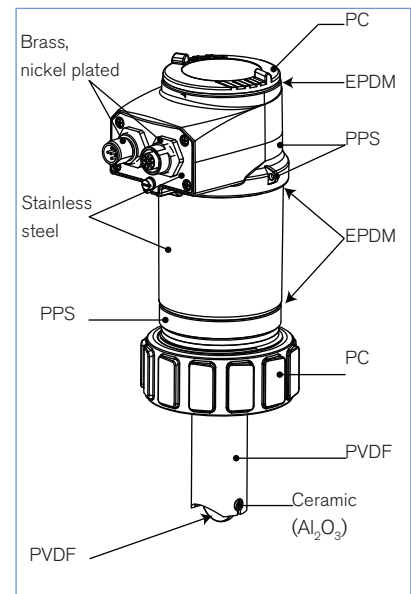

* For the 97/23/CE pressure directive, the device can only be used under following conditions (depend on max. pressure, pipe diameter and fluid).

Type of fluid	Conditions
Fluid group 1, §1.3.a	DN ≤ 25 only
Fluid group 2, §1.3.a	DN ≤ 32 DN > 32 and PN*DN ≤ 1000
Fluid group 1, §1.3.a	DN ≤ 25 DN > 25 and PN*DN ≤ 2000
Fluid group 2, §1.3.a	DN ≤ 400

Principle of operation

When liquid flows through the pipe, the paddle-wheel with 4 inserted magnets is set in rotation, producing a measuring signal in the sensor (Hall sensor). The frequency modulated induced voltage is proportional to the flow velocity of the fluid.

A conversion coefficient (K-factor, available in the instruction manual of the S020 fitting), specific to each pipe (size and material) enables the conversion of this frequency into flow rate.



The electronic component converts the measured signal into several outputs (according to the transmitter version) and displays the actual value. Counters are used to obtain the volume of fluid passed through the pipe.

In-line installation

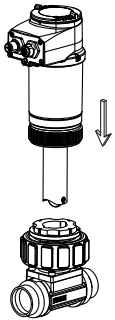

The 8026 flow transmitter can easily be installed into any Bürkert INSERTION fitting system (S020), by just fixing the main nut.

Minimum straight upstream and downstream distances must be observed. According to the pipe's design, necessary distances can be bigger or use a flow conditioner to obtain the best accuracy.

For more information, please refer to EN ISO 5167-1.

EN ISO 5167-1 prescribes the straight inlet and outlet distances that must be complied with when installing fittings in pipe lines in order to achieve calm flow conditions. The most important layouts that could lead to turbulence in the flow are shown below, together with the associated prescribed minimum inlet and outlet distances.

These ensure calm, problem-free measurement conditions at the measurement point.

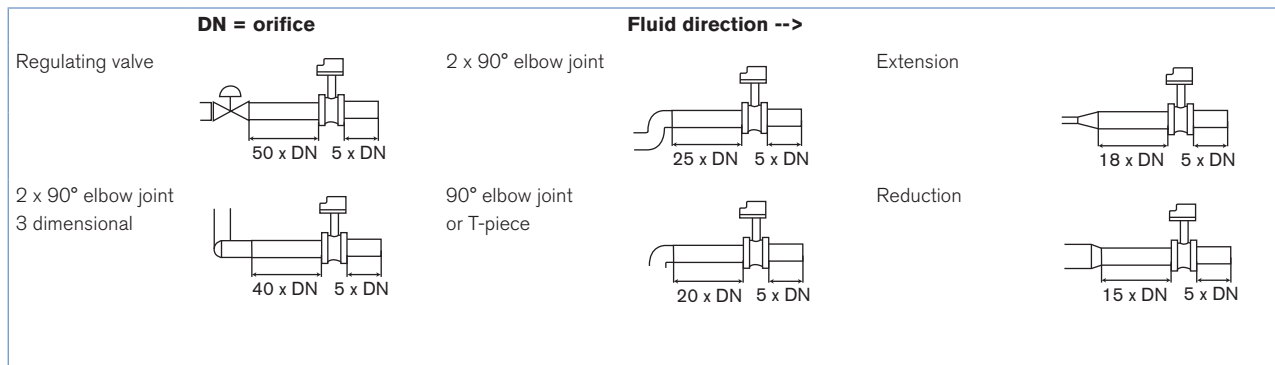

The flow rate sensor can be installed into either horizontal or vertical pipes.

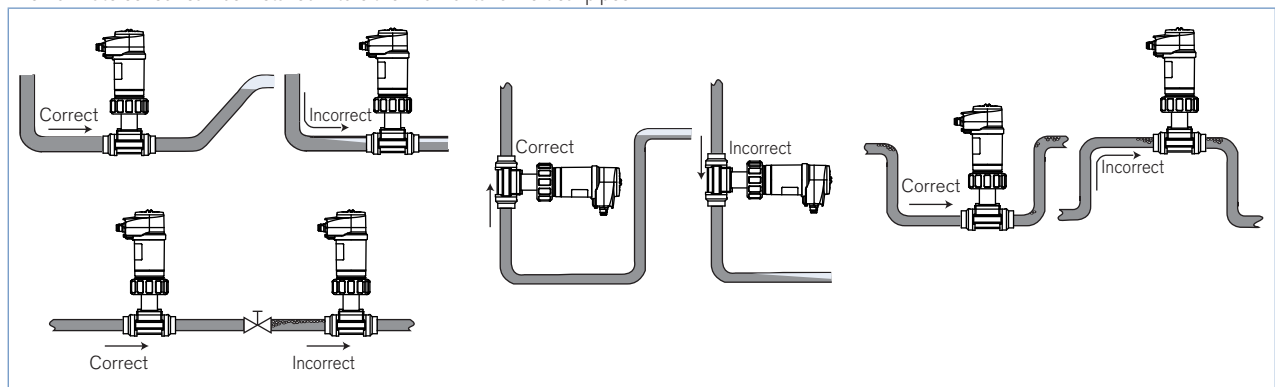

Pressure and temperature ratings must be respected according to the selected fitting material.

The suitable pipe size is selected using the diagram Flow / Velocity / DN.

The flow transmitter is not designed for gas flow measurement. Selection of fitting / pipe size

Selection of fitting / pipe size

Example:

- Specification of nominal flow: 10 m³/h
- Ideal flow velocity: 2...3 m/s

For these specifications, the diagram indicates a pipe size of DN40 [or DN50 for (*) mentioned fittings]

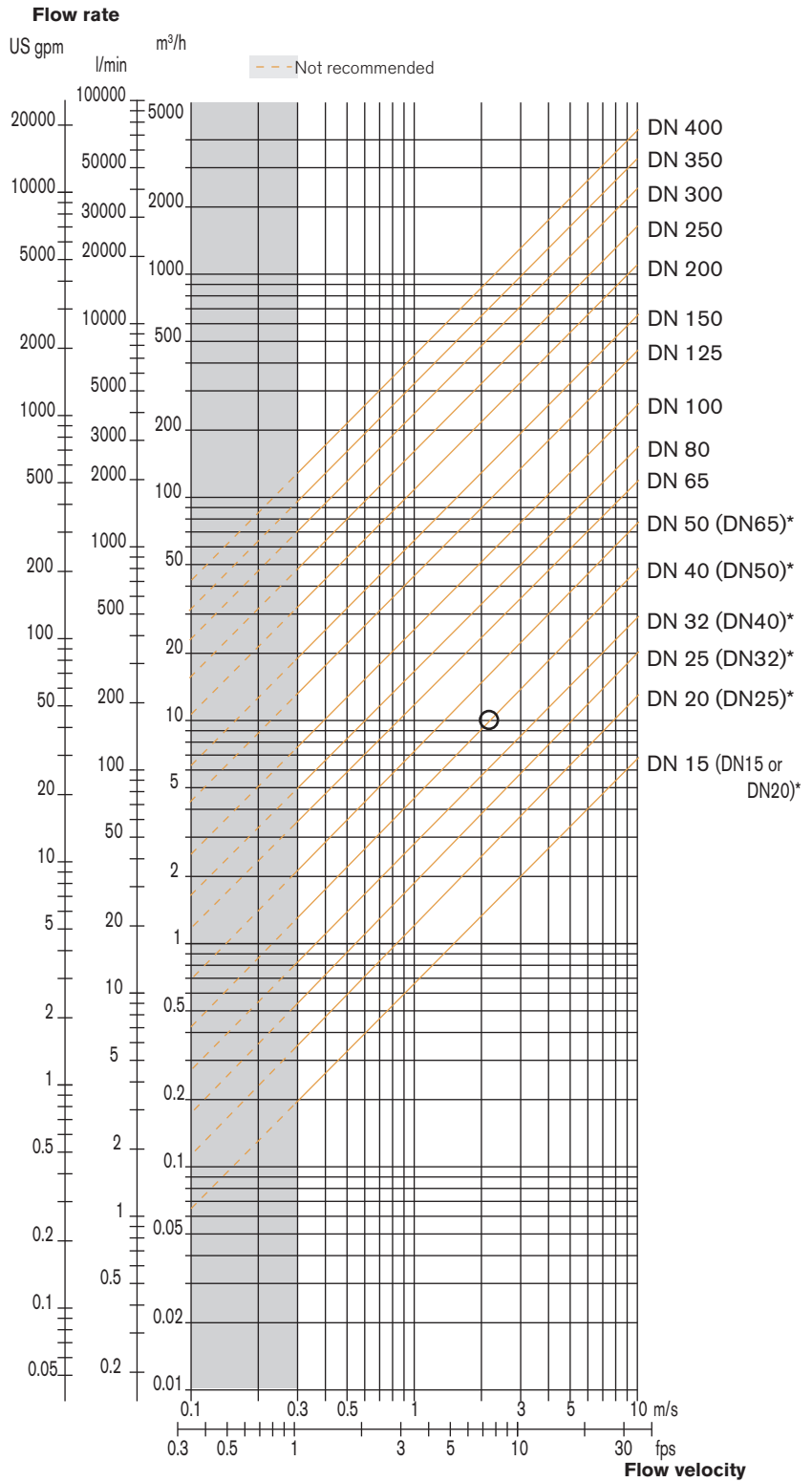

* For following fittings:
 - with external threads acc. to SMS 1145
 - with weld-ends acc. to SMS 3008, BS 4825 / ASME BPE or DIN 11850 Series 2
 - with Clamp acc. to SMS 3017 / ISO 2852, BS 4825 / ASME BPE or DIN 32676

DTS 1000128706 EN Version: E Status: RL (released | freigegeben | valide) printed: 19.01.2015

Dimensions [mm] of transmitter Type 8026

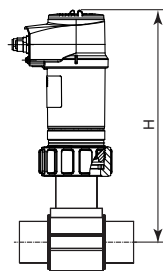
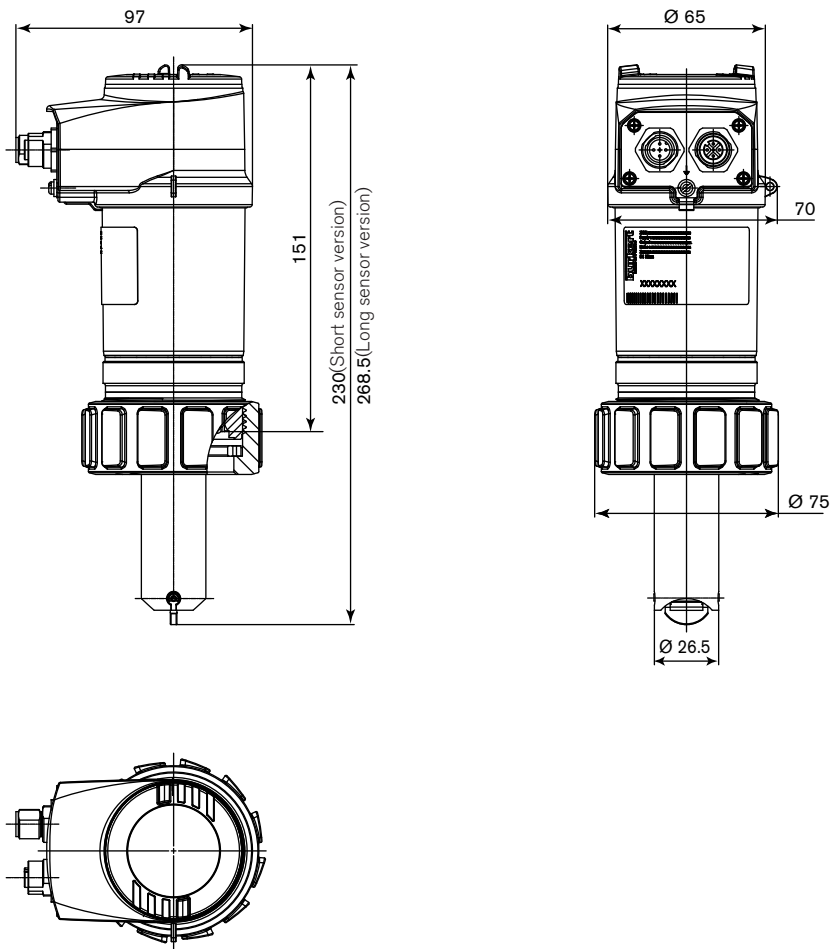

DN [mm]	H with S020 fitting [mm]			
	T-Fitting	Saddle	Plastic spigot	Metal spigot
15	231.5			
20	229.5			
25	229.5			
32	232.5			
40	236.5			
50	242.5	267.5		237.5
65	242.5	265.5	250.5	243.5
80		270.5	256.5	248.5
100		275.5	263.5	258.5
110		271.5		
125		278.5	298.5	269.5
150		248.5	305.5	280.5
180		312.5		
200		324.5	326.5	301.5
250			344.5	361.5
300			356.5	380.5
350			369.5	392.5
400			384.5	

Ordering information for compact transmitter Type 8026

A complete flow transmitter with integrated paddle-wheel sensor Type 8026 consists of a compact flow ELEMENT transmitter Type 8026, a removable display/programmer and a Bürkert INSERTION fitting Type S020

The following information is necessary for the selection of a complete device:

- **Item no.** of the desired compact flow transmitter **Type 8026** (see ordering chart on p. 7)
- **Item no.** of the selected INSERTION fitting **Type S020** (see separate data sheet)



You have always to order separately two components.

Attention!

When you order devices without display, please take care that you also order at least one display module for the operation.

Order no. of the removable display / programming module (see ordering chart on p. 7)

When you click on the orange box "More info." below, you will come to our website for the resp. product where you can download the data sheet.

Example

Compact transmitter with display Type 8026



Compact transmitter without display Type 8026



Removable display/programmer



INSERTION fitting Type S020







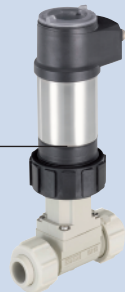

More info.

Complete flow transmitter Type 8026



Ordering chart for compact flow transmitter Type 8026





Specifications	Voltage supply	Output	Sensor version	Electrical connection	UL Approvals	Item no.	
						without display	with display
2 outputs	14-36 V DC	1 x transistor NPN + 1 x 4-20 mA (2-wire)	Short	5-pin M12 male fixed connector	No	560 860	561 860
					 Recognized	560 863	561 863
			Long	5-pin M12 male fixed connector	No	560 870	561 870
					 Recognized	560 873	561 873
3 outputs	14-36 V DC	2 x transistors NPN/ PNP + 1 x 4-20 mA (2-wire)	Short	5-pin M12 male fixed connector	No	560 861	561 861
					 Recognized	560 864	561 864
			Long	5-pin M12 male fixed connector	No	560 871	561 871
					 Recognized	560 874	561 874
4 outputs	12-36 V DC	2 x transistors NPN/ PNP + 2 x 4-20 mA (3-wire)	Short	5-pin M12 male and 5-pin M12 female fixed connectors	No	560 862	561 862
					 Recognized	560 865	561 865
			Long	5-pin M12 male and 5-pin M12 female fixed connectors	No	560 872	561 872
					 Recognized	560 875	561 875

Note: FKM gasket in standard; 1 Kit including a black EPDM gasket and a mounting instruction sheet is supplied with each transmitter.

Note: Order separately (see accessories)

- M12 cable plugs (only female for one 4-20 mA output, 1 male + 1 female for two 4-20 mA outputs transmitter)

Ordering chart for accessories

Description	Item no.
Removable display/programmer module (with instruction sheet)	559 168
Black blank cover with EPDM seal	560 948
Transparent cover with EPDM seal	561 843
Ring	619 205
Nut	619 204
Set with 1 green FKM and 1 black EPDM gasket	552 111
 5 pin M12 female straight cable plug with plastic threaded locking ring, to be wired	917 116
 5 pin M12 male straight cable plug with plastic threaded locking ring, to be wired	560 946
 5 pin M12 female straight cable plug moulded on cable (2 m, shielded)	438 680
 5 pin M12 male straight cable plug moulded on cable (2 m, shielded)	559 177

Interconnection possibilities with other Bürkert devices

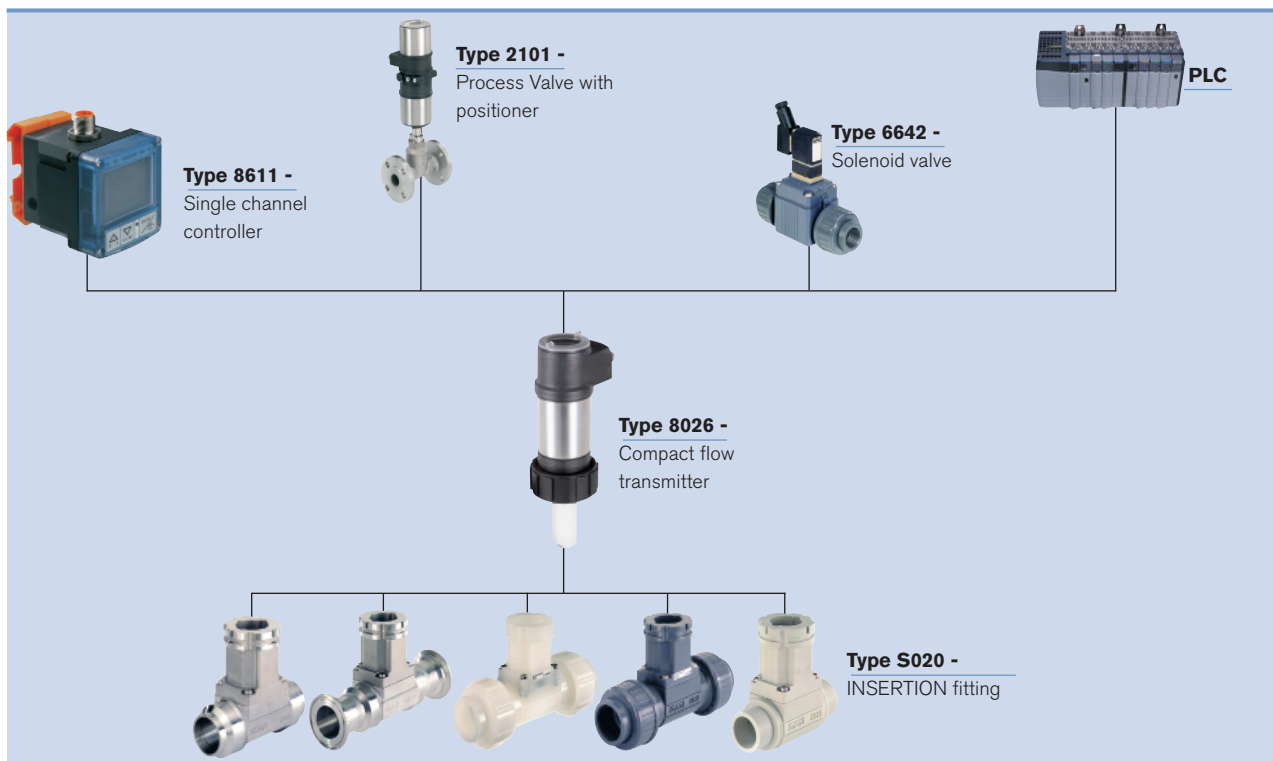

DTS 1000128706 EN Version: E Status: RL (released | freigegeben | validé) printed: 19.01.2015

To find the nearest Bürkert, click on the orange box →

www.burkert.com

In case of special application conditions,
please consult for advice.

Subject to alteration
© Christian Bürkert GmbH & Co. KG

1407/5_EU-en_00895129