



Digital flow transmitter for continuous flow measurement

- Compact version for DN06 to DN65
- Displays both flow rate and volume (with two totalizers)
- Automatic calibration: Teach-In
- Simulation: all output signals provided without the need for real flow

Type 8035T can be combined with...



Type S030
INLINE fitting

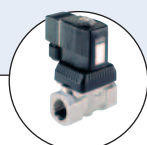

Type 6213
Solenoid valve



Type 2712 (8630)
Continuous
TopControl system

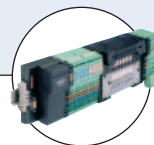

Type 8644
Valve islands

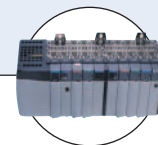

PLC

The flow transmitter is specially designed for use in neutral, slightly aggressive, solid free liquids. The transmitter is made up of a compact fitting with paddle-wheel (S030) and an electronic module (SE35) quickly and easily connected together by a Quarter-Turn.

The Bürkert designed fitting system ensures simple installation of the sensors into all pipes from DN06 to DN65.

The device is available in different models:

- Flow transmitter with standard output signal
- Battery powered

Technical data															
General data															
Compatibility	with fittings S030 (see corresponding data sheet)														
Materials	<table border="0"> <tr> <td>Housing, cover, lid, nut</td> <td>PC</td> </tr> <tr> <td>Front panel foil / Screws</td> <td>Polyester / Stainless steel</td> </tr> <tr> <td>Cable plug or glands</td> <td>PA</td> </tr> <tr> <td>Wetted parts materials</td> <td></td> </tr> <tr> <td> Fitting, sensor armature</td> <td>Brass, stainless steel 1.4404/316L, PVC, PP or PVDF</td> </tr> <tr> <td> Paddle-wheel</td> <td>PVDF</td> </tr> <tr> <td> Axis and bearing / Seal</td> <td>Ceramics / FKM (EPDM included but non-mounted)</td> </tr> </table>	Housing, cover, lid, nut	PC	Front panel foil / Screws	Polyester / Stainless steel	Cable plug or glands	PA	Wetted parts materials		Fitting, sensor armature	Brass, stainless steel 1.4404/316L, PVC, PP or PVDF	Paddle-wheel	PVDF	Axis and bearing / Seal	Ceramics / FKM (EPDM included but non-mounted)
Housing, cover, lid, nut	PC														
Front panel foil / Screws	Polyester / Stainless steel														
Cable plug or glands	PA														
Wetted parts materials															
Fitting, sensor armature	Brass, stainless steel 1.4404/316L, PVC, PP or PVDF														
Paddle-wheel	PVDF														
Axis and bearing / Seal	Ceramics / FKM (EPDM included but non-mounted)														
Display	15x60 mm, 8-digit LCD, alphanumeric, 15 segments, 9 mm high														
Electrical connections	Cable plug EN175301-803 or cable glands M20x1.5 or none (for battery version) max. 50 m, shielded cable with 1.5 mm ² max. cross-section														
Complete device data (Fitting S030 + electronics)															
Pipe diameter	DN06 to DN65														
Measuring range	0.5 m/s to 10 m/s (Battery version - Coil transducer) 0.3 m/s to 10 m/s (Hall transducer version)														
Fluid temperature with fitting in PVC / PP PVDF, brass or stainless steel	0°C to 50°C (32°F to 122°F) / 0°C to 80°C (32°F to 176°F) -15°C to 100°C (5°F to 212°F)														
Fluid pressure max.	PN10 (145.1PSI) (with plastic fitting) - PN16 (232.16PSI) (with metal fitting - PN40 on request, see S030 data sheet) - see Pressure/Temperature diagram														
Viscosity / Pollution	300 cSt. max. / 1% max. (size: 0.5 mm max.)														
Measurement error Teach-In Standard K-factor	±1% of Reading ¹⁾ (at the teach flow rate value) ±2.5% of Reading ¹⁾														
Linearity	±0.5% of F.S.* ¹⁾														
Repeatability	±0.4% of reading ¹⁾														

¹⁾ Under reference conditions i.e. measuring fluid=water, ambient and water temperature=20°C (68°F), applying the minimum inlet and outlet pipe straights, matched inside pipe dimensions * F.S.=Full scale (10 m/s)

8035 Transmitter INLINE

Electrical data

Power supply (V+) Standard signal version	12-36 V DC $\pm 10\%$, filtered and regulated, SELV (extra low safety voltage) circuit with a non dangerous energy level or 115/230 V AC 50/60 Hz (see technical specifications 115/230 V AC)
Battery indicator/totalizer version	2 x 9 V DC batteries, lifetime min. 1 year at 20°C (68°F)
Reversed polarity of DC	protected
Current consumption with sensor (without consumption of pulse output)	≤ 70 mA at 12 V DC - transmitter with relays ≤ 25 mA at 12 V DC - transmitter without relay
Output Standard signal version Signal current	4-20 mA (3-wire with relays; 2-wire without relay) max. loop impedance: 900 Ω at 30 V DC; 600 Ω at 24 V DC; 50 Ω at 12 V DC; 800 Ω with a 115/230 V AC voltage supply
Pulse	Polarized, potential free, 5...36 V DC; 100 mA, protected, line drop at 100 mA: 2.5 V DC
Relay	2 relays, freely configurable, 3 A, 230 V AC
Battery indicator/totalizer version	None
4... 20 mA measurement error	$\pm 1\%$

Environment

Height above sea level	max. 2000 m
Ambient temperature (operation and storage)	0°C to +60°C (32°F to 140°F) (12-36 V DC or battery version) 0°C to +50°C (32°F to 122°F) (115/230 V AC version)
Relative humidity	$\leq 80\%$, without condensation

Technical specifications 115/230 V AC

Voltage supply available inside the device	27 V DC regulated, max. current: 125 mA integrated protection: fuse 125 mA temporised power: 3 VA
--	---

Standard, directives and approvals

Protection class	IP65 with cable plug or gland mounted and tightened or with obturator locked if not used.
Standard EMC Safety Pressure (Fitting S030, DN06 to DN65, in PVC, PP, PVDF, stainless steel or brass) Vibration / Shock	EN 61000-6-2, EN 61000-6-3 EN 61010-1 Complying with article 3 of chap. 3 from 2006/95/CE directive* EN 60068-2-6 / EN 60068-2-27

* For the 2006/95/CE pressure directive, the device can only be used under following conditions (depend on max. pressure, pipe diameter and fluid).

Type of fluid	Conditions
Fluid group 1, chap. 1.3.a	DN25 only
Fluid group 2, chap. 1.3.a	DN ≤ 32 , or DN > 32 and PN*DN ≤ 1000
Fluid group 1, chap. 1.3.b	PN*DN ≤ 2000
Fluid group 2, chap. 1.3.b	DN ≤ 200

Specific technical data of UL-recognized products for US and Canada

Relay output	30 V AC and 42 V peak max. or 60 V DC max.
Ambient temperature	0°C to +40°C (32°F to 104°F)
Relative humidity	max. 80%, without condensation
Intended for an inner pollution	Grade of pollution 2
Installation category	Category I

Pressure/Temperature diagram

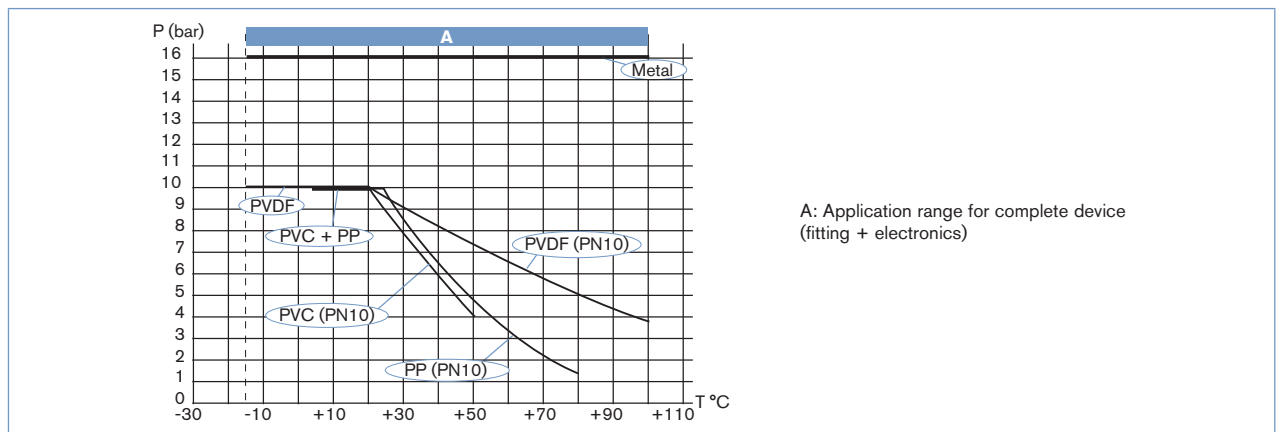

Operation and display

The device can be calibrated by means of the K-factor, or via the Teach-In function. User adjustments, such as measuring range, engineering units, pulse output and filtering level are carried out on the site. The operation is specified according to two or three levels, depending on the transmitter version:

	Indication in operating mode / display	Parameter definition	Test
Flow transmitter	<ul style="list-style-type: none"> flow rate output current main totalizer daily totalizer with reset function 	<ul style="list-style-type: none"> language engineering units K-factor / Teach-In function measuring range 4-20 mA pulse output relay (option) filter reset main totalizer 	<ul style="list-style-type: none"> alteration of basic adjustment (offset, span) frequency test of sensor flow simulation
Battery indicator/totalizer	<ul style="list-style-type: none"> flow rate main totalizer daily totalizer with reset function 	<ul style="list-style-type: none"> language engineering units K-factor / Teach-In function filter reset main totalizer 	

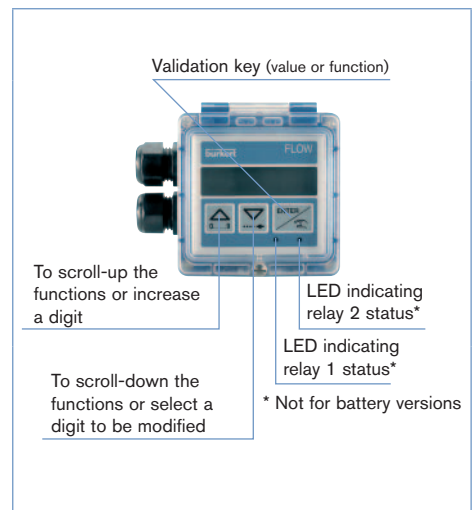

Design and principle of operation



The electronic housing of the 8035 integrates the electronic board with display, setting parameter keys and also a transducer (coil for battery indicator version or Hall for other versions). The paddle-wheel is mounted in the fitting. The output signals are provided via a cable plug or two cable glands (according to the transmitter version). Bürkert designed fitting ensures simple installation of the Bürkert transmitter into pipes from DN06 to DN65.

When liquid flows through the pipe, the 4 magnets, inserted in the paddle-wheel set in rotation, produce a measuring signal in the transducer. The frequency modulated induced voltage is proportional to the flow velocity of the fluid. A conversion coefficient (K-factor, available in the instruction manual of the S030 fitting), specific to each pipe (size and material) enables the conversion of this frequency into a flow rate. The electronic component converts the measured signal into several outputs (according to the transmitter version) and displays the actual value.

Installation

The SE35 electronic can easily be installed into any Bürkert INLINE fitting system (S030) by means of a Quarter-Turn.

Minimum straight upstream and downstream distances must be observed. According to the pipe's design, necessary distances can be bigger or use a flow conditioner to obtain the best accuracy. For more information, please refer to EN ISO 5167-1.

EN ISO 5167-1 specifies the straight inlet and outlet distances that must be complied with when installing fittings in pipelines in order to achieve calm flow conditions.

The most important layouts that could lead to turbulence in the flow are shown below, together with the associated minimum inlet and outlet distances. These ensure calm, problem-free measurement conditions at the measurement point.

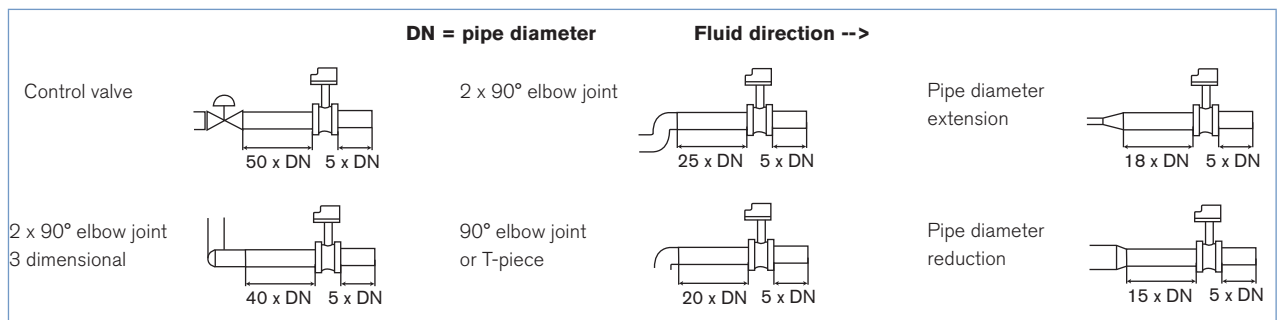

8035 Transmitter INLINE



The flow transmitter can be installed into either horizontal or vertical pipes.

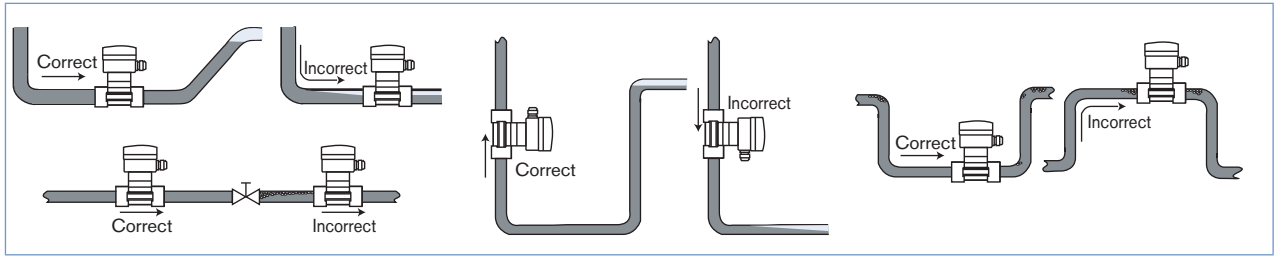

Pressure and temperature ratings must be respected according to the selected fitting material.
 The suitable pipe size is selected using the diagram Flow/Velocity/DN.
 The flow transmitter is not designed for gas flow measurement.

Diagram Flow/Velocity/DN

Example:

- Specification of nominal flow: 10 m³/h
- Ideal flow velocity: 2...3 m/s

For these specifications, the diagram indicates a pipe size of DN40 [or DN50 for (*) mentioned fittings]

Flow rate

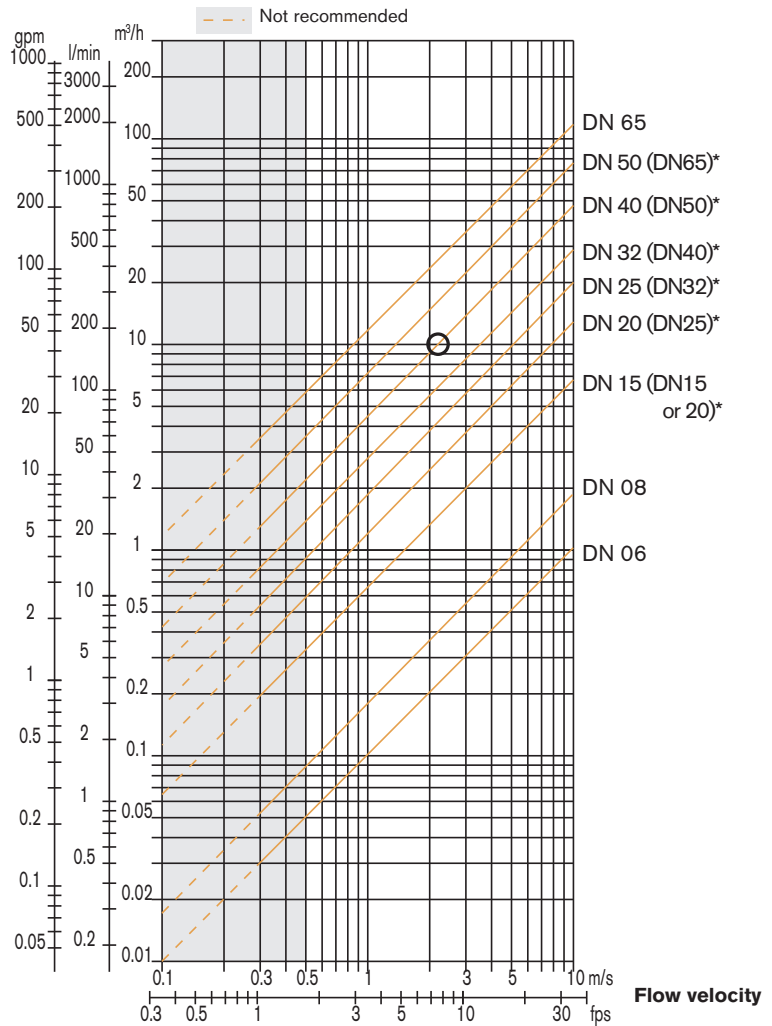

- * for following fittings with:
- external threads acc. to SMS 1145
- weld ends acc. to SMS 3008, BS 4825 / ASME BPE or DIN 11850 Series 2
- Clamp acc. to SMS 3017/ ISO 2852, BS 4825 / ASME BPE or DIN 32676

Dimensions [mm]

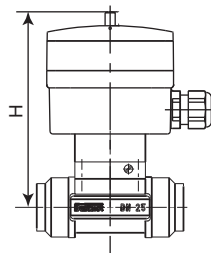
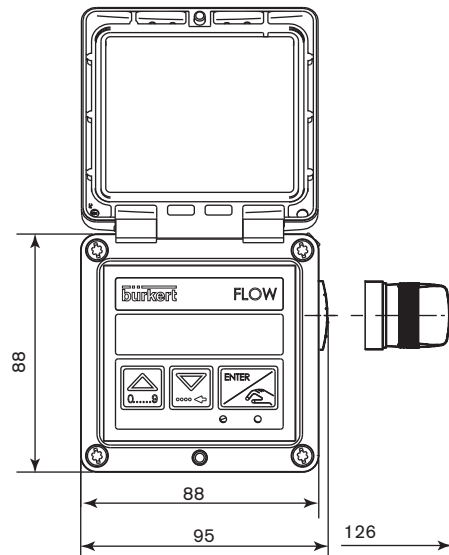
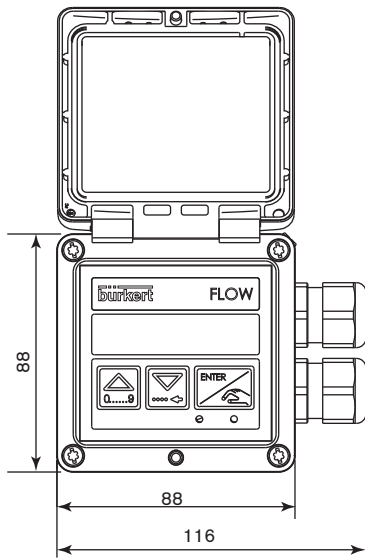
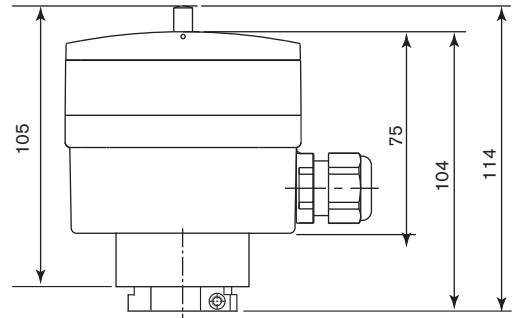
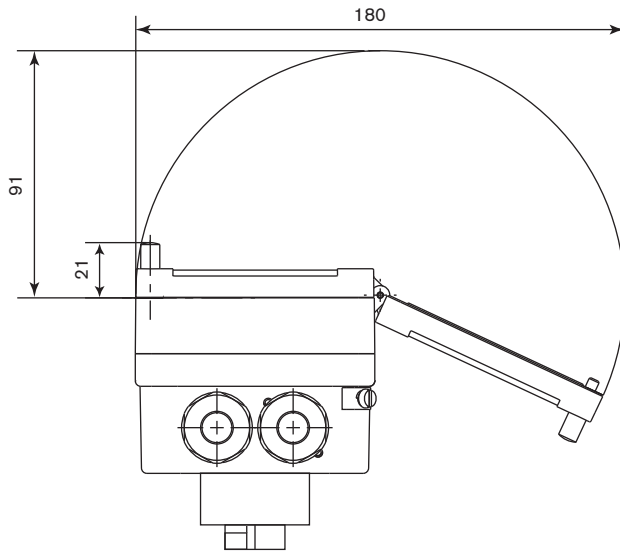



DN	H
06	134
08	134
15	139
20	137
25	137
32	140
40	144
50	151
65	151

Ordering chart for transmitter Type 8035

Flow transmitter or indicator/totalizer with integrated paddle-wheel sensor

A flow transmitter or indicator/totalizer Type 8035 consists of:

- an INLINE electronics Type SE35
- an INLINE fitting Type S030 (DN06-DN65) (Refer to corresponding data sheet - has to be ordered separately)

Specifications	Voltage supply	Outputs	Relays	Sensor version	Agreements	Electrical connection	Item no.
Standard output signal transmitter, 2 totalizers	12-36 V DC	4-20 mA (2-wires) + pulse	None	Hall	-	EN 175301-803	444 005
						2 cable glands	444 006
		UL-Recognized for US and Canada 	2 cable glands	553 432			
	115/230 V AC	4-20 mA (3-wires) + pulse	2	Hall	-	2 cable glands	444 007
					UL-Recognized for US and Canada 	2 cable glands	553 433
		4-20 mA (2-wires) + pulse	None	Hall	-	2 cable glands	423 922
Indicator, 2 totalizers	2 x 9 V DC Batteries	4-20 mA (3-wires) + pulse	2	Hall	-	2 cable glands	423 924
		-	None	Coil	-	None	423 921

Ordering chart - accessories for transmitter Type 8035 (has to be ordered separately)

Specifications	Item no.
Set with 2 cable glands M20x1.5 + 2 neoprene flat seals for cable gland or plug + 2 screw-plugs M20x1.5 + 2 multiway seals 2x6 mm	449 755
Set with 2 reductions M20x1.5 /NPT1/2" + 2 neoprene flat seals for cable gland or plug + 2 screw-plugs M20x1.5	551 782
Set with 1 stopper for unused cable gland M20x1.5 + 1 multiway seal 2x6 mm for cable gland + 1 black EPDM seal for the sensor + 1 mounting instruction sheet	551 775
Cable plug EN 175301-803 with cable gland (Type 2508)	438 811
Cable plug EN 175301-803 with NPT1/2" reduction without cable gland (Type 2509)	162 673

Interconnection possibilities with other Bürkert products

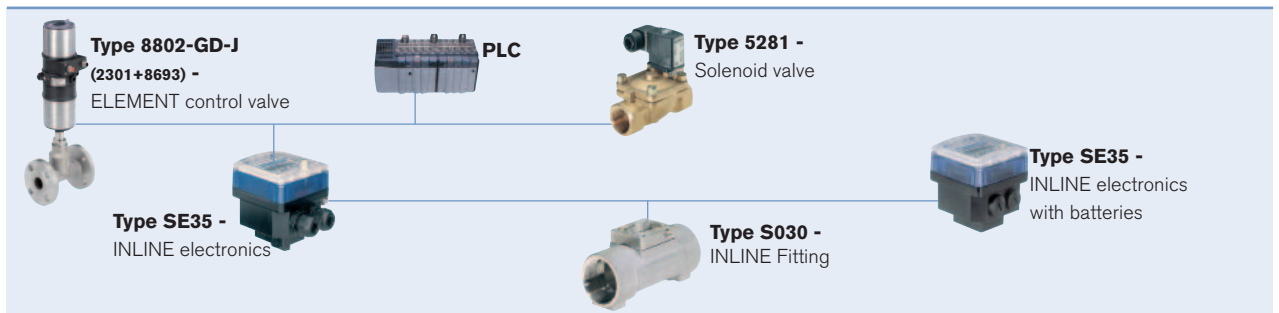

To find your nearest Bürkert facility, click on the orange box →

www.burkert.com

In case of special application conditions, please consult for advice.

Subject to alteration.
© Christian Bürkert GmbH & Co. KG

1401/10_EU-en_00891786