



Type 8690 can be combined with...



Type 2100

Angle seat valve



Type 2101

Globe valve



Type 2103

Diaphragm valve



Type 2000

Angle seat valve

Pneumatic Control Unit for the integrated mounting on process valves

- Compact design
- Pilot valve with high air flow rate
- Internal control air channel
- Visual position indicator
- With ATEX II cat. 3G/D and cat. 2D/G approval

The 8690 pneumatic control unit is optimised for integrated mounting on the 21XX process valve series. Mechanical or inductive limit switches register the position of the valve. The integrated pilot valve controls single or double-acting actuators.

The design of the control unit and the actuator enables an internal control air channel without external tubings. Besides the electrical position feedback signal the status of the device is shown directly on the control head itself.

The housing is easy to clean and features proven electrical IP protection and chemically resistant materials for use in hygienic processing, in food, beverage and pharmaceutical industries. Combined with Bürkert ELEMENT actuators the unique pilot valve system enables a compressed air recycling that avoids actuator chambers contamination from the environment.

Technical Data	
Material - Body Cover Sealing	PPS PC EPDM
Operating voltage * Pilot valve Micro switch Initiator	24 V DC $\pm 10\%$ residual ripple 10 % DC Consumption 1W max. 24 VDC, max. 2A 10 to 24 VDC, max. 100mA ext. load per initiator According to Fieldbus specification
Control medium Dust concentration Particle density Pressure condensation point Oil concentration	Neutral gases, air DIN ISO 8573-1 Class 5 (<40 μ m particle size) Class 5 (<10mg/m ³) Class 3 (<-20°C) Class 5 (<25mg/m ³)
Supply pressure	3 to 7 bar ¹⁾
Air input filter Mesh aperture	Exchangeable ~0.1mm
Pilot air ports	Threaded ports G1/8, stainless steel or push-in connector (tube \varnothing 6 mm or 1/4")
Position feedback	1 or 2x micro switch (24 VDC) 1 or 2x initiator 3-wires (24 VDC) 1 or 2x initiator NAMUR (8 VDC) (ATEX II 2G Ex ia IIC T6)
Stroke range valve spindle Micro switch Initiator	7 to 28 mm 2 to 28 mm
Ambient temperature with pilot valve Without pilot valve	-10 to +55 °C -20 to +60 °C
Installation	As required, preferably with actuator in upright position
Protection type	IP65 and IP67 acc. to EN 60529, Type 4X
Protection class	3 acc. to VDE 0580
Conformity	According to CE in compliance with EMV2004/108/EG
Approvals	ATEX II cat. 3G/D and cat. 2D/G cULus Cert. No. 238179
Ignition protection:	II 3D Ex tc IIC T135°C Dc II 3G Ex nA IIC T4 Gc II 2G Ex ia IIC T* Gb II 2D Ex ia IIC T135°C Db IP64
Electrical connection Multipole Cable gland	M12, 8-pole M16x1,5 (cable- \varnothing 10mm), screw terminals (1,5mm ²)

* Supply voltage according to UL NEC Class 2 for versions with cULus approval.

¹⁾ The supply pressure has to be 0,5 - 1 bar above the minimum required pilot pressure for the valve actuator.

Ordering information for process valve system with integrated pneumatic control unit

A complete process valve system consists of a pneumatic control unit Type 8690 and a process valve Type 21xx or 20xx.

The following information is necessary for the selection of a complete system:

- **Item no.** of the desired pneumatic control unit **Type 8690** (see Ordering chart on p. 3)

- **Item no.** of the selected process valve **Type 21xx or Type 20xx**

(see separate datasheet for e.g. Types 2100, 2101, 2103 and 2000, 2012, 2031)

You order two components and receive a complete assembled and certified valve.

Click on the orange box "More info." below... you will come to our website for the resp. product where you can download the datasheet.

Example for process valve systems

Pneumatic control unit
Type 8690

Desired process valve, example



Mehr
Infos

2100
Angle seat
valve



Mehr
Infos

2103
Diaphragm
valve

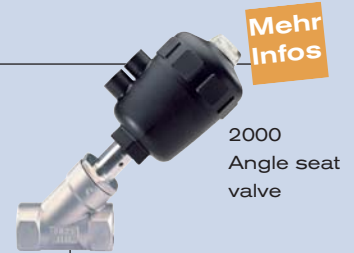

Mehr
Infos

2000
Angle seat
valve

Complete process valve system



Valve system
On/Off ELEMENT
Type 8801-YE-K
2100 + 8690



Valve system
On/Off ELEMENT
Type 8801-DF-K
2103+8690



Valve system
On/Off Classic
Type 8801-YA-K
2000 + 8690

Ordering chart pneumatic control unit Type 8690 (other versions on request)

End position feedback			Electrical connection	Control function	Pilot air ports threaded ports	Item no.			
Inductive switch 24 VDC PNP	Inductive switch NAMUR 2-wire 8V DC Ex ia IIC T6	Micro switch 24V DC				Standard	ATEX II cat. 3G/D	ATEX II cat. 2G/D	
Actuator series ELEMENT Type 21xx process valves									
2			M12 multipole	single-acting	G1/8	227 222	264 968		
2				double-acting	G1/8	264 939	264 957		
2					G1/8	227 190	264 949		
2			Cable gland	single-acting	G1/8	227 220	264 967		
2				double-acting	G1/8	264 941	264 956		
2					G1/8	227 189	264 948		
1			M12 multipole	single-acting	G1/8	227 218	264 964		
1				double-acting	G1/8	264 940	264 953		
1					G1/8	265 151	264 945		
1			Cable gland	single-acting	G1/8	227 216	264 963		
1				double-acting	G1/8	264 942	264 952		
1					G1/8	265 154	264 944		
	2			single-acting	G1/8			265 143	
	2			double-acting	G1/8			265 144	
	2				G1/8			265 142	
		2	M12 multipole	single-acting	G1/8	227 234			
		1			G1/8	227 230			
		2	Cable gland	single-acting	G1/8	227 232			
		2			G1/8	227 195			
without end position feedback			Cable gland	single-acting	G1/8	225 883	264 961		
				double-acting	G1/8	265 156	265 935		
Actuator series CLASSIC Type 20xx process valves									
2			M12 multipole	single-acting	G1/8	227 226	264 970		
2				double-acting	G1/8	265 148	264 959		
2						227 193	264 951		
2			Cable gland	single-acting	G1/8	227 224	264 969		
2				double-acting	G1/8	227 207	264 958		
2						227 192	264 950		
1			M12 multipole	single-acting	G1/8	265 149	264 966		
1				double-acting	G1/8	265 150	264 955		
1						228 286	264 947		
1			Cable gland	single-acting	G1/8	265 152	264 965		
1				double-acting	G1/8	265 153	264 954		
1						227 188	264 946		
	2			single-acting	G1/8			265 146	
	2			double-acting	G1/8			265 147	
	2							265 145	
		2	M12 multipole	single-acting	G1/8	227 238			
		2					227 200		
		1					228 282		
		2	Cable gland	single-acting	G1/8	227 236			
		2		double-acting	G1/8	227 213			
		2					227 198		
without end position feedback			Cable gland	single-acting		265 936	264 962		

Note: All non-ATEX versions are UL approved.

i Further versions on request



Approvals
FM



Additional
push-in pilot air ports (tube Ø 6mm / 1/4")

Ordering chart adapter kit (has to be ordered separately)

Description	Actuator size	Control function	Item no.
Adapter kit ELEMENT Type 21xx	Ø70/90/130 mm	Universal	665 720
Adapter kit CLASSIC Type 20xx	Ø63 mm	Universal	673 262
		feedback (without pilot valve)	677 203
	Ø80 mm	universal	673 263
		feedback (without pilot valve)	677 204
	Ø100 mm	Universal	673 264
		feedback (without pilot valve)	677 205
	Ø125 mm	Universal	674 513
		feedback (without pilot valve)	677 205
Ø175/225 mm	Universal	see Control Unit, Type 8691	
	feedback (without pilot valve)	see Control Unit, Type 8697	

Accessories

Description	Item no.
M12 socket, 8-pins, 5 m assembled cable	919 267
M12 socket, 4-pins, 5 m assembled cable	918 038
M12 socket, 5-pins, 5 m assembled cable	264 606
ASI flat cable clip with stainless steel socket M12 (spare part)	799 646
Silencer G1/8	780 779
Silencer, push-in connector	902 662

Materials

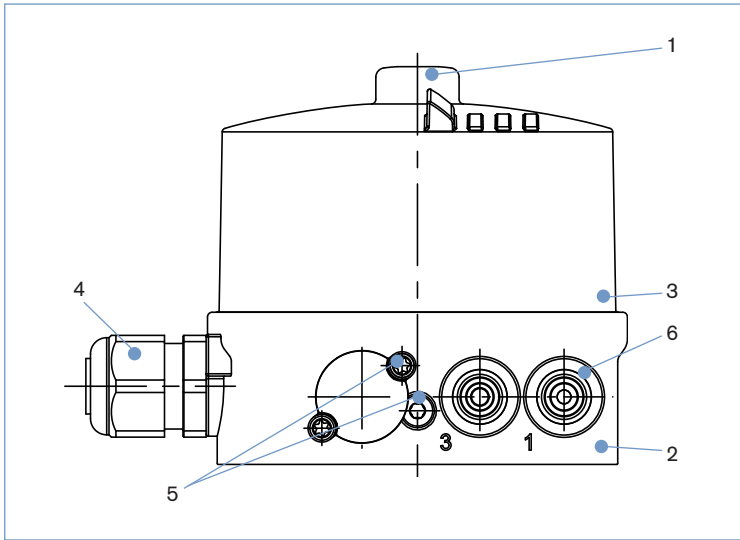

- 1 Transparent cap** PC
- 2 Basic body** PPS
- 3 Sealing** EPDM
- 4 Cable connection Plug** PA
M12 Stainless steel
- 5 Screws** Stainless steel
- 6 Push-in connector Threaded ports G1/8** POM/Stainless steel
Stainless steel

Dimensions [mm]

Mounting on process valve, ELEMENT Type 21xx

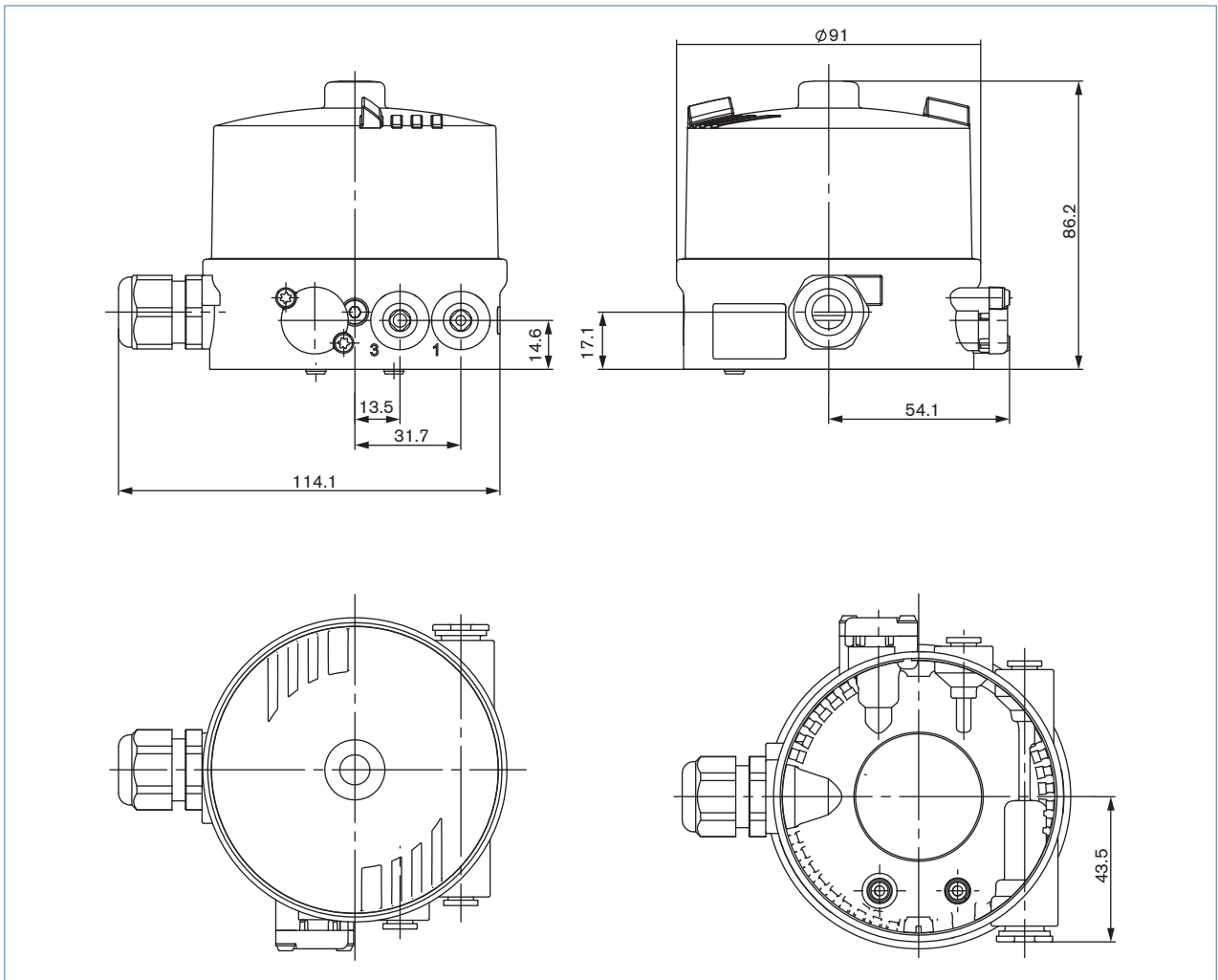

Dimensions [mm]

Mounting on process valve, CLASSIC Type 20xx

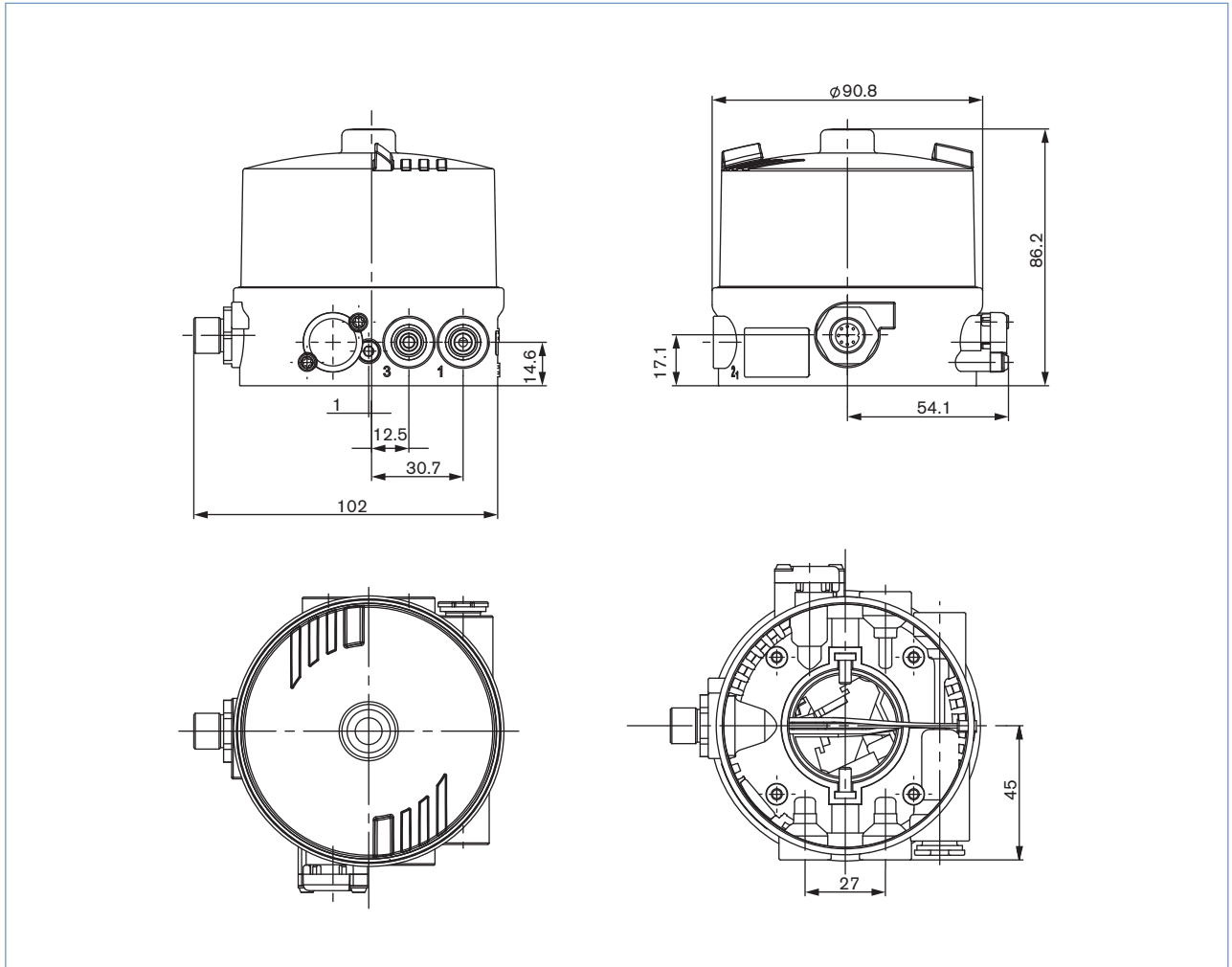

Connection options

Multipole, plug M12 8-pins

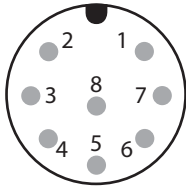

Plug configuration 24 V with micro switch

Pin no.	Configuration	External Circuitry
1	Micro switch top (NO)	Micro switch top (NO)
3		
2	Micro switch bottom (NO)	Micro switch bottom (NO)
4		
5	Valve control 0/24 V	0/24 V DC \pm 10 % Residual ripple 10 %
6	Valve control GND	
7	Not configured	
8	Not configured	

Plug configuration with initiator

Pin no.	Configuration
1	INI 1 OUT Output
2	INI 2 OUT Output
3	INI - (GND) Supply
4	INI + (24 V DC) Supply
5	Valve control 0 / 24 V DC
6	Valve control GND

Cable gland

M16 x 1,5 (cable- \varnothing 10 mm), screw terminals (1,5 mm²)

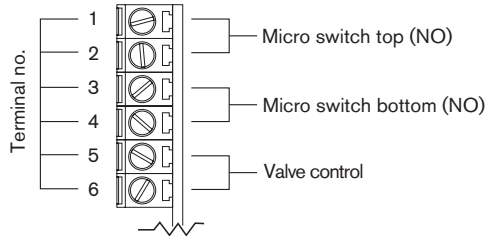

Port configuration 24 V with micro switch

Pin no.	Configuration	External Circuitry
1	Micro switch top (NO)	1 Micro switch top (NO)
2		
3	Micro switch bottom (NO)	3 Micro switch bottom (NO)
4		
5	Valve control 0/24 V	0/24 V DC \pm 10 % Residual ripple 10 %
6	Valve control GND	

Port configuration with initiator

Clamp no.	Configuration
1	INI - (GND) Supply
2	INI 1 OUT Output
3	INI 2 OUT Output
4	INI + (24 V DC) Supply
5	Valve control 0 / 24 V DC
6	Valve control GND

Port configuration with 2-Wire inductive proximity switches NAMUR

Clamp no.	Configuration	External Switching
1	INI Top +	<div style="display: flex; justify-content: space-between;"> <div style="width: 45%;"> <p>Ex protection area</p> <p>NAMUR-Sensor</p> </div> <div style="width: 45%; border-left: 1px dashed black; padding-left: 10px;"> <p>non-explosive area</p> </div> </div>
2	INI Top -	
3	INI Bottom +	
4	INI Bottom -	
5	Valve control +	
6	Valve control GND	

Tab. 4: Pin Assignment with 2 Wire initiator

¹⁾ (acc. to Namur recommendation) also note the certificate of Fa. Turck KEMA 02 ATEX 1090X

²⁾ Signal from barriers see PTB 07 ATEX 2048

DTS 1000108879 EN Version: L Status: RL (released | freigegeben | validé) printed: 24.04.2015

To find your nearest Bürkert facility, click on the orange box → www.burkert.com

In case of special application conditions, please consult for advice

Subject to alterations.
© Christian Bürkert GmbH & Co. KG

1504/9_EU-en_00895080